

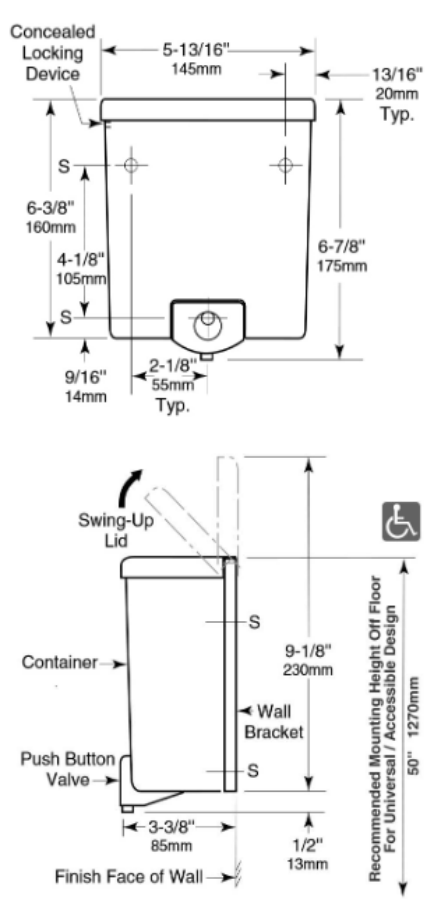

PROJECT		REF		REV	ITEM CODE	
LOCATION		DATE			PAGE	

## SANITARY WARE SPECIFICATION SHEET

<p><b>Item Descriptions</b></p> <p>Bobrick (USA) surface mounted push button soap dispenser in black finish (1.2L)</p>	<p><b>Model</b> B-42</p> <p><b>Dimensions</b> L145 x W85 x H175 mm</p> <p><b>Material</b> Plastic</p> <p><b>Manufacturer</b> Bobrick Washroom Equipment Inc. (USA)</p> <p><b>Source</b> Ka Shing Enterprises (H.K) Limited Mr. Ivan Lau / Mr. GilmanYuen</p> <p><b>Contact Tel/Fax</b> (852) 2628-0661 / (852) 2490-2700</p> <p><b>E-mail</b> project@kashingehk.com</p> <p><b>Website</b> www.kashingehk.com</p>	<p style="text-align: center;"><b>Illustration/ Drawing</b></p>  
<p><b>MATERIAL:</b></p> <p><b>Valve</b> — Black, high-impact-resistant ABS push button and spout. Soap head-holding mushroom valve. Stainless steel spring, U-packing seal and duckbill.</p> <p><b>Wall Bracket</b> — Black, high-impact-resistant ABS. Equipped with a concealed locking device to secure the lid and a removable plastic key to disengage locking device.</p> <p><b>Container</b> — Black, translucent ABS. Capacity: 40-fl oz (1.2-L).</p> <p><b>Lid</b> — Black, high-impact-resistant ABS.</p>		
<p><b>OPERATION:</b> Corrosion-resistant valve dispenses commercially marketed all-purpose hand soaps. Valve is operable with one hand, without tight grasping, pinching, or twisting of the wrist, and with less than 5 pounds of force (22.2 N) to comply with accessible design (including ADAAG in U.S.A.). Large-capacity, translucent container provides visible soap level. To fill container, use the plastic key provided or any small pointed object to push in the concealed locking device located at upper left side of wall bracket; lid will automatically pop forward. Lid swings up to top fill only after lock is disengaged. After filling, swing lid down and push it toward the wall; a click sound confirms lid is locked. Soap container is removable for maintenance or replacement by opening the lid, pushing back on the container stop spring tab and sliding the container up off the wall bracket. Replace the lid before mounting the container onto the wall bracket.</p>		

**Note:**

\* All information of the above is for the reference only. No prior notice is made if any changes.