

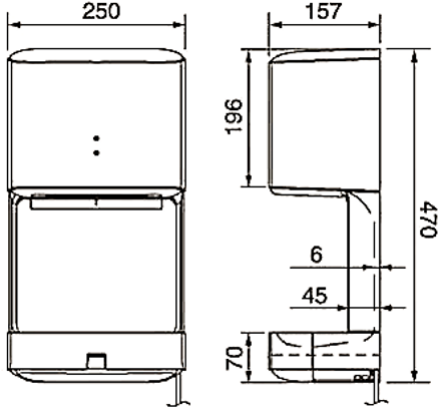

PROJECT		REF		REV	ITEM CODE	
LOCATION		DATE			PAGE	

SANITARY WARE SPECIFICATION SHEET

<p>Item Descriptions</p> <p>Model</p> <p>Dimensions</p> <p>Material</p> <p>Manufacturer</p> <p>Source</p> <p>Contact Tel/Fax</p> <p>E-mail</p> <p>Website</p>	<p>KDK automatic switch hand dryer with water tray, 220V, infra-red motion</p> <p>T09AC</p> <p>H471 x W251 x D158 mm</p> <p>Plastic</p> <p>CASATINO (PRC)</p> <p>Ka Shing Enterprises (H.K) Limited Mr. Ivan Lau / Mr. GilmanYuen (852) 2628-0661 / (852) 2490-2700 project@kashingehk.com www.kashingehk.com</p>	<p>Illustration/ Drawing</p>  
<p>Unique drain pan and water tray</p> <p>Infra-red motion sensor</p> <p>Safety check light function</p> <p>Auto-stop feature for overheat protection</p> <p>Color: White</p> <p>Powerful air velocity of 100 meter/second</p> <p>Infra-red motion sensor</p> <p>Super Alleru-Buster Filter</p> <p>Anti-bacteria casing material</p> <p>Supply with metal mounthing plate</p> <p>Size(mm): 470(H) x 250(W) x 157(D)</p> <p>Frequency: 50 Hertz(Hz)</p> <p>Velocity 100Meter per second (m/s)</p> <p>Noise: 62 Decibel (dB(A))</p> <p>Installion: Wall Mount</p> <p>Power Consumption: 1020 Wattage (W)</p> <p>Voltage: 220 Voltage (V)</p> <p>Net Weight: 4 Kilogtam (kg)</p>		

Note:



SINCE 1909
JAPAN



Hand Dryer

NEW
ECO DRY



T09AC



T09BC



New Features

Compact Design

As compared with previous model, the depth of new model is 4.8% reduced. The slim shape allows the product to be installed in narrow space of washroom easily.

Spacious Drying Chamber

By adopting newly developed nozzle shape and compact-sized motor, the depth and height of hand drying chamber are increased about 28% in volume.

In addition, the shape of drying chamber is carefully designed that the possibility of touching the inner surface of drying chamber is minimized. It allows you to have a clean hand drying process always.

*1 As compared with previous models

*2 As compared with volume 6.0L of T09AC and 4.7L of previous model T09AB

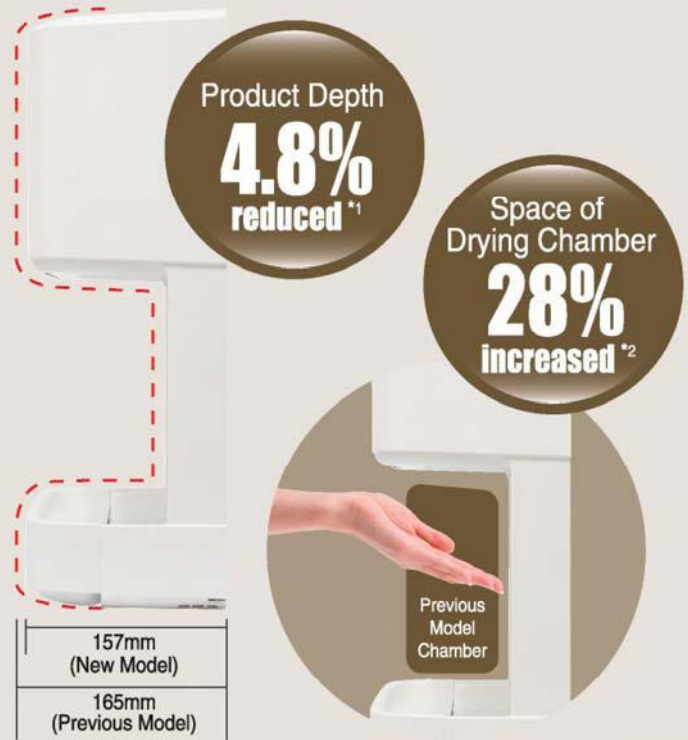

Quick Drying with 3-way Airflow

Wide Nozzle

Blow off water droplets on the whole palm with wide airflow

Spot Nozzle

Dry fine water droplets by rubbing hands with spot airflow



Wide & Spot Nozzle

2 kinds of nozzle, wide nozzle and spot nozzle, are equipped at front and rear of drying chamber respectively for efficient drying. The new structure realizes quick drying in only 4~9 seconds.



Water Tank Capacity

30% increased^{*3}



Detachable Drain Pan Unit

Drain outlet can be detached from drain pan unit for cleaning that hygiene is easily maintained. Capacity of water tank is about 30% increased as compared with previous model, that time for maintenance is reduced.

*3 As compared with water tank capacity 0.8L of T09AC and 0.6L of previous model T09AB

Total Cost Comparison (Monthly)

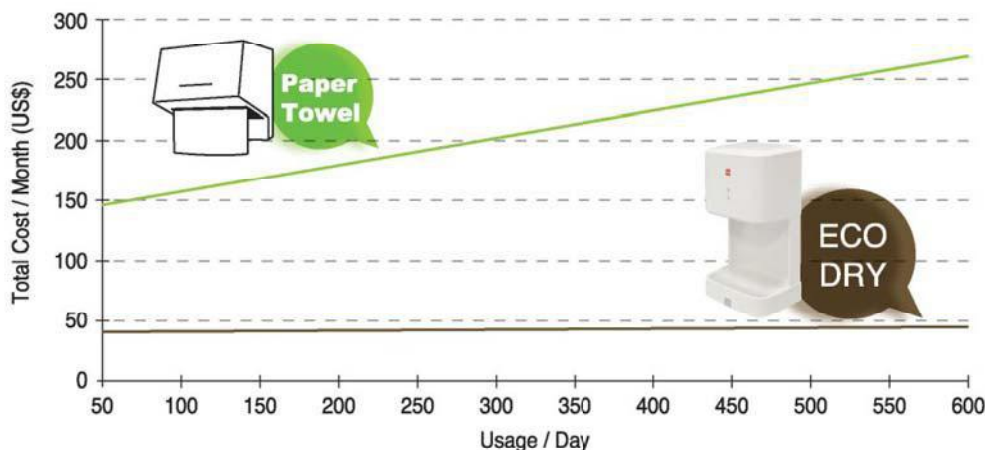

Remarks:
Data are based on Hong Kong Market situation and used for reference only

Advantages



Super alleru-buster Filter

- The filter is equipped to ensure the air blow to your hand is clean

Anti-bacteria Material

- The product body is adopted with anti-bacteria material to prevent the growth of bacteria and germs in the warm and humid environment of washroom

Safe Operation

- Eco Dry will stop after 60 seconds of continuous operation
- "Check" indicator will light up when the unit detects overheated

Quick Response Sensor

- Automatic sensor operation, no physical contact is required to activate the unit

Heater ON/OFF Switch

- Heater can be switched off for energy saving in hot season

(T09AC only)

Drain Pan

- Drain pan can reduce water dripping on floor to avoid slippery

Full Tank Indicator

- Remind you for cleaning up the water tank when it is full

Easy Installation

- Metallic bracket for wall hanging attached
- Stylish and streamline design fits most interior

Cost Calculation Base On 50 Usage Per Day (US\$)

	Material Cost	Labor Cost	Total Cost
Washroom with Paper Towel	Paper towel costs \$0.0074/pieces 1 paper towels are used each time Monthly Cost = \$0.0074 x 50(usage) x 30(day) = \$11.10	Labor cost for cleaning = \$4.52/hr Twice a day, 30 min./time = 30 hrs/month Monthly Cost = \$4.52 x 30 = \$135.60	Material Cost + Labor Cost = \$11.10 + \$135.60 = \$146.70
Washroom with Hand Dryer	Power consumption costs \$0.13 per kwh Operates 9 sec. per usage = 0.0025 hr Cost/usage = \$0.13 x 0.0025 = \$0.00033 Monthly Cost = \$0.00033 x 50(usage) x 30(day) = \$0.50	Labor cost for cleaning = \$4.52/hr Once a day, 15 min./time = 7.5 hrs/month Monthly Cost = \$4.52 x 7.5 = \$33.90	Material Cost + Labor Cost = \$0.50 + \$33.90 = \$34.40

What is Super Alleru-Buster?

Super alleru-buster can inhibit up to several types of allergen

Testing Organization: The Osaka Municipal Technical Research Institute.
Testing Method: to measure the level of reduction in cat's dandruff by Enzyme-linked Immuno Sorbent Assay.

Phenolic Polymer • Polyphenol



Environmental Friendly

Avoiding irregular use of paper towels that favours the environment.



Hygiene

Keep your hands dry and hygienic.

Cleanliness

Wet floor and paper towel disposal will disappear after the installation of Hand Dryer.



T09AC		220V 50/60Hz	230V 50/60Hz
Power Consumption [W]	Heater ON	1,020	1,070
	Heater OFF	650	700
Air Velocity [m/s]		90 - 110	90 - 110
Drying Time [second]		4 - 9	4 - 9
Noise [dB(A)]		62	62
Drain Pan		Yes	
Weight [kg]		4	

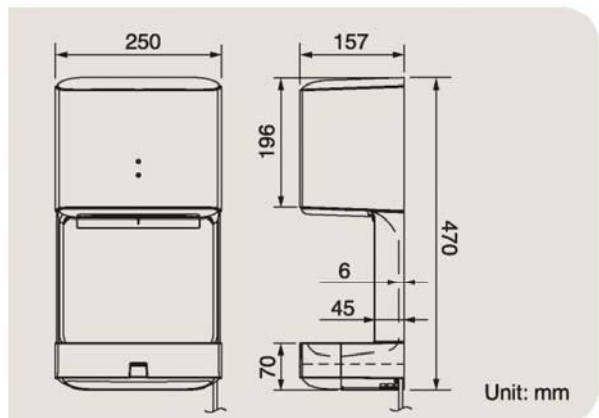

T09BC		220V 50/60Hz	230V 50/60Hz
Power Consumption [W]	Heater ON	1,020	1,070
	Heater OFF	650	700
Air Velocity [m/s]		90 - 110	90 - 110
Drying Time [second]		4 - 9	4 - 9
Noise [dB(A)]		62	62
Drain Pan		No	
Weight [kg]		3.5	

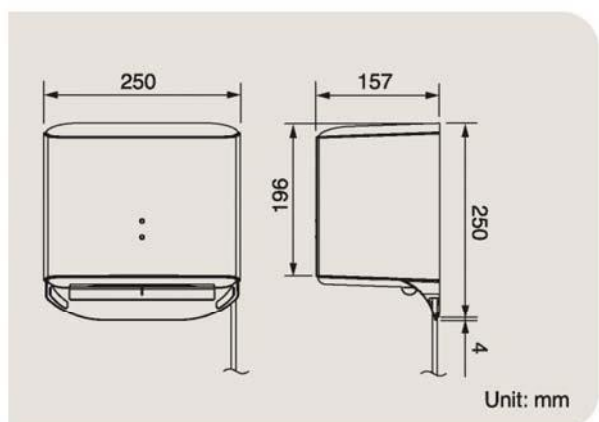

KDK Company, Division of PES
4017, Takaki-cho, Kasugai, Aichi, Japan
<http://kdk.jp>

• Specifications are subject to change without prior notice.
• Actual colors may vary slightly from those shown.

CATALOG NO:K-HD001B1
Printed in Hong Kong 06.14