





PROJECT		REF		REV	ITEM CODE	
LOCATION		DATE			PAGE	

SANITARY WARE SPECIFICATION SHEET

<p>Item Descriptions</p> <p>Delabie (France) "BINOPTIC" Wall-mounted electronic liquid soap dispenser with 230/6V transformer 1-litre</p> <p>Model 512051BK</p> <p>Spout length 115mm</p> <p>Material Matte black 304 stainless steel</p> <p>Manufacturer Delabie (France)</p> <p>Source Ka Shing Enterprises (H.K.) Limited Mr. Ivan Lau / Mr. GilmanYuen</p> <p>Contact Tel/Fax (852) 2628-0661 / (852) 2490-2700</p> <p>E-mail project@kashingehk.com</p> <p>Website www.kashingehk.com</p>	<p>Illustration/ Drawing</p>  <ul style="list-style-type: none"> Total hygiene: no manual contact Comfort: automatic soap dispenser No waste pump dispenser Liquid or foam soap or hydroalcoholic gel 																
<p>DESCRIPTION</p> <p>BINOPTIC wall-mounted electronic soap dispenser Ref. 512051P (Chrome-plated 304 stainless steel) Ref. 512051S (Satin finish 304 stainless steel) Ref. 512051BK (Matte black 304 stainless steel) Wall-mounted electronic soap dispenser. Liquid or foam soap or hydroalcoholic gel dispenser. No manual contact: infrared cell detects hands automatically. Matte black 304 stainless steel spout. No waste pump dispenser. Independent electronic housing and removable tank enable installation beneath the washbasin. Automatic soap dispenser: mains supply with 230/6V transformer. For vegetable-based liquid soap with maximum viscosity of 3,000 mPa.s or specific foam soap. Compatible with hydroalcoholic gel Total spout length: 115mm. Supplied with 1-litre tank.</p> 	<p>TECHNICAL CHARACTERISTICS</p> <p>BINOPTIC wall-mounted electronic soap dispenser - Ref. 512051BK</p> <table border="1"> <tr> <td>Supply</td> <td>Mains 230/6V</td> </tr> <tr> <td>Technology</td> <td>Infrared sensor</td> </tr> <tr> <td>Height</td> <td>333mm (tank + electronic unit)</td> </tr> <tr> <td>Length</td> <td>115mm</td> </tr> <tr> <td>Spout length</td> <td>98mm</td> </tr> <tr> <td>Volume</td> <td>1 litre tank</td> </tr> <tr> <td>Finish</td> <td>Matte black 304 stainless steel</td> </tr> <tr> <td>Norms</td> <td>CE</td> </tr> </table> 	Supply	Mains 230/6V	Technology	Infrared sensor	Height	333mm (tank + electronic unit)	Length	115mm	Spout length	98mm	Volume	1 litre tank	Finish	Matte black 304 stainless steel	Norms	CE
Supply	Mains 230/6V																
Technology	Infrared sensor																
Height	333mm (tank + electronic unit)																
Length	115mm																
Spout length	98mm																
Volume	1 litre tank																
Finish	Matte black 304 stainless steel																
Norms	CE																

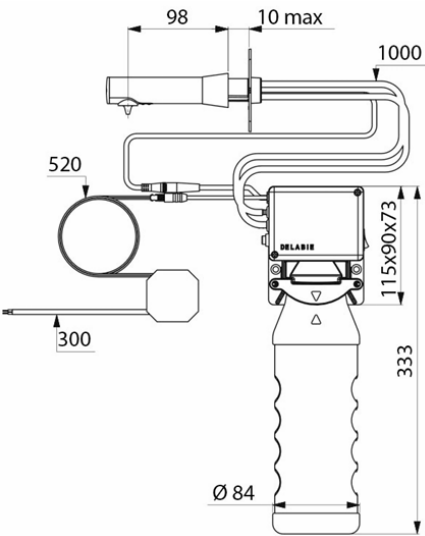
Note:

* All information of the above is for the reference only. No prior notice is made if any changes.

