



PROJECT		REF		REV	ITEM CODE	
LOCATION		DATE			PAGE	

SANITARY WARE SPECIFICATION SHEET

<p>Item Descriptions</p> <p>Dimensions</p> <p>Model</p> <p>Materials</p> <p>Manufacturer</p> <p>Source</p> <p>Contact Tel/Fax</p> <p>E-mail</p> <p>Website</p>	<p>Koala Kare (USA) Wall mounted polyethylene child protection seat ; European Standards: EN 12221 Changing units for domestic use.</p> <p>L311 x W317 x H476 mm</p> <p>KB102-00 (Cream Color) KB102-01 (Grey Color)</p> <p>Polyethylene</p> <p>Koala Kare (USA)</p> <p>Ka Shing Enterprises (H.K) Limited Mr. Ivan Lau / Mr. GilmanYuen</p> <p>(852) 2628-0661 / (852) 2490-2700 project@kashingehk.com www.kashingehk.com</p>	<p>Illustration/ Drawing</p>
<p>KB102 Child Protection Seat</p> <p>Koala’s child protection seat allows parents to comfortably secure a child while tending to siblings and other matters in restrooms and fitting rooms. Steel pivot rod secured in aluminum tube hinge mechanism provides superior support and wear resistance. Textured seat surface with nylon safety straps that extends over child’s shoulders and between legs for security. Closed unit folds to less than 6" (143 mm), and requires less than 2 sq. ft (1858 sq. cm) of wall space. Designed to support a child 50 pounds or less (22.7 kilograms). Polyethylene seat surface exclusively contains Microban® antimicrobial, reducing odor causing bacteria. Constructed with 31% recycled materials; contributes to LEED certified building requirements.</p> <p>Colors</p> <p> </p> <p>Grey 01 Cream 00</p>		

Note:

* All information of the above is for the reference only. No prior notice is made if any changes.



PROJECT		REF		REV	ITEM CODE	
LOCATION		DATE			PAGE	

SANITARY WARE SPECIFICATION SHEET

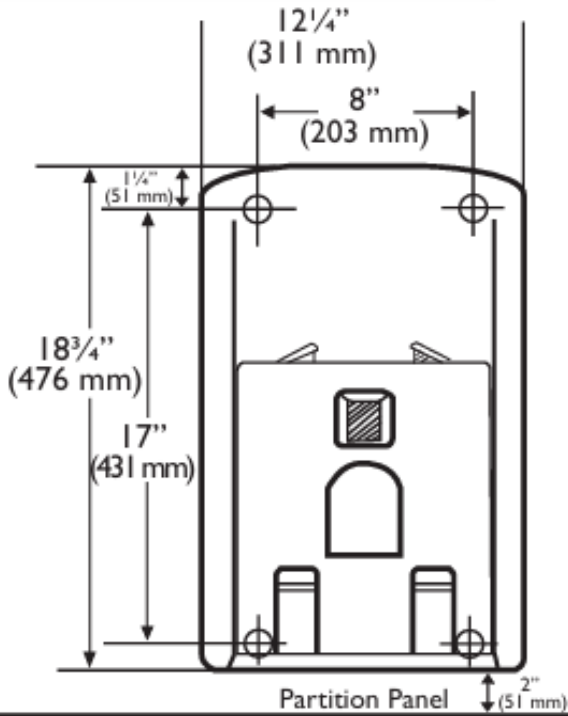

Mount 2" (51 mm) from bottom of door or 14" (356 mm) from floor

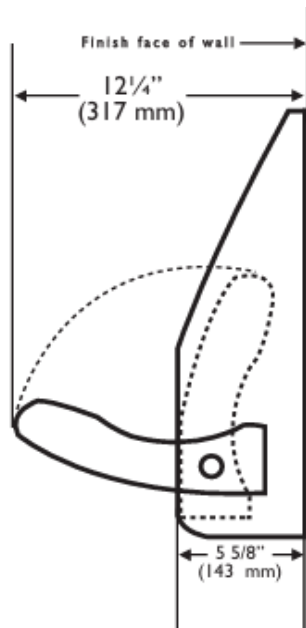
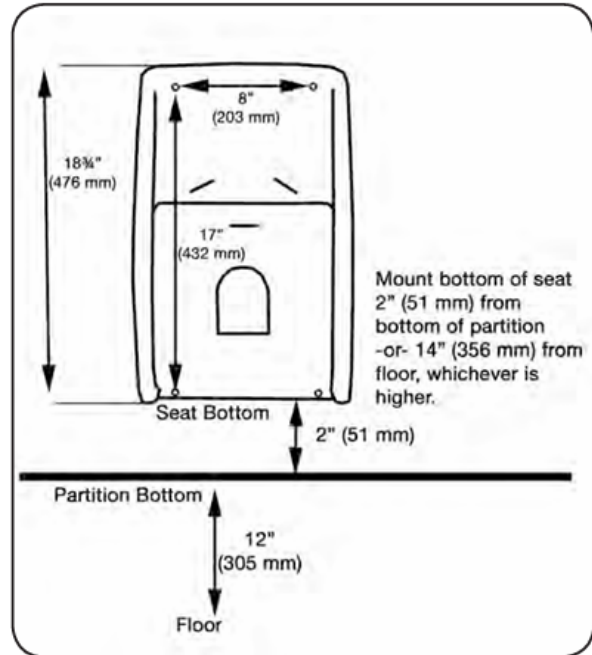

Insert Barrel Bolts from outside of partition wall. Use supplied hardware shown.

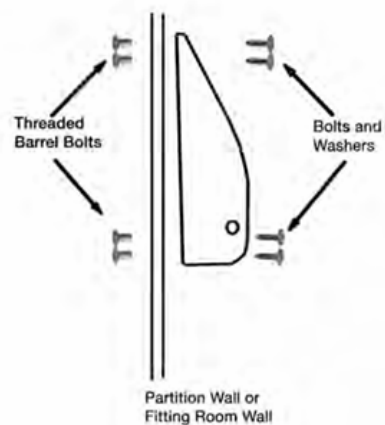

Unit Dimensions:
 Height: 18 3/4" (476 mm)
 Width: 12 1/4" (311 mm)
 Depth: 5 5/8" (143 mm) closed
 Depth: 12 1/4" (311 mm) open

Note:

* All information of the above is for the reference only. No prior notice is made if any changes.