



PROJECT		REF		REV	ITEM CODE	
LOCATION		DATE			PAGE	

SANITARY WARE SPECIFICATION SHEET

<p>Item Descriptions</p> <p>Dimensions</p> <p>Model</p> <p>Materials</p> <p>Manufacturer</p> <p>Source</p> <p>Contact Tel/Fax</p> <p>E-mail</p> <p>Website</p>	<p>Koala Kare (USA) Horizontal wall mounted polyethylene baby changing station ; European Standards: EN 12221;ISO 22196 tested for efficacy</p> <p>L912 x W539 x H527 mm</p> <p>KB300-00 (Beige Color) KB300-01 (Grey Color) KB300-05 (White Granite Color)</p> <p>Polyethylene</p> <p>Koala Kare (USA)</p> <p>Ka Shing Enterprises (H.K) Limited Mr. Ivan Lau / Mr. GilmanYuen</p> <p>(852) 2628-0661 / (852) 2490-2700 project@kashingehk.com www.kashingehk.com</p>	<p style="text-align: center;">Illustration/ Drawing</p> <div style="display: flex; justify-content: space-between;"> </div>
<p>KB300 Horizontal Surface-Mounted</p> <p>Surface-mounted horizontal baby changing station is constructed of polypropylene and features a unibody steel chassis for superior strength. Available in three stunning colors with each providing a modern visual aesthetic. Thoughtful patron amenities enhance the end-user experience, and include Microban® product protection, a redesigned liner dispenser and the Koala brand mark that communicates comfort to families and the promise of a thoughtful accommodation.</p> <p>The dual liner cavity has an internal spring tab that pushes liners forward while only allowing single liner dispensing. Each cavity holds 25 liners and locking mechanism minimizes operator refills and discourages potential vandalism. The product includes child protection straps. Bed surface exclusively contains Microban® antimicrobial product protection that reduces odor causing bacteria and keeps the bed surface cleaner between cleanings. Concealed pneumatic cylinder provides controlled, slow opening and closing of the changing station bed.</p> <p>This Baby Changing Station has been tested to support 200 lbs with minimal deflection. Please note: This product is designed for infants only, up to 3.5 years of age and weighing less than 50 lbs. ASTM and EN compliant. Meets ADA requirements when mounted properly.</p>		
<p>Colors</p> <div style="display: flex; justify-content: space-around; align-items: center;"> <div style="text-align: center;"> <p>Beige 00</p> </div> <div style="text-align: center;"> <p>Grey 01</p> </div> <div style="text-align: center;"> <p>White Granite 05</p> </div> </div>		

Note:

** All information of the above is for the reference only. No prior notice is made if any changes.*



Ka Shing Enterprise (H.K.) Ltd.

ROOM 1706 NEW TERRITORIES TSUEN WAN HO LIK CENTRE, 66A SHA TSUI ROAD

Tel:26280661 Fax: 24902700

Email: project@kashingehk.com

Website: www.kashingehk.com

PROJECT		REF		REV	ITEM CODE	
LOCATION		DATE			PAGE	

SANITARY WARE SPECIFICATION SHEET

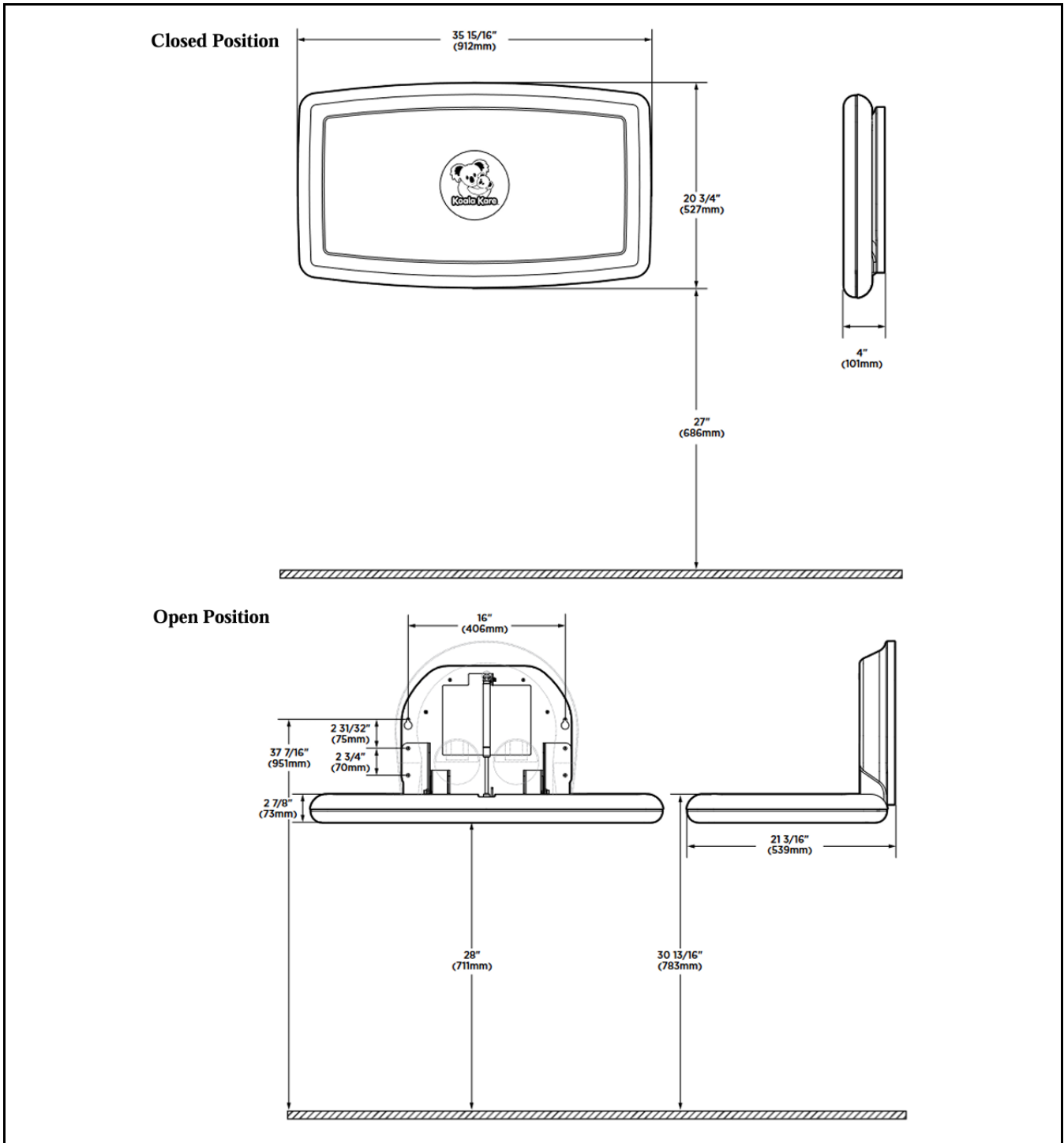

Note:

* All information of the above is for the reference only. No prior notice is made if any changes.



Ka Shing Enterprise (H.K.) Ltd.

ROOM 1706 NEW TERRITORIES TSUEN WAN HO LIK CENTRE, 66A SHA TSUI ROAD
Tel:26280661 Fax: 24902700
Email: project@kashingehk.com
Website: www.kashingehk.com

PROJECT		REF		REV	ITEM CODE	
LOCATION		DATE			PAGE	

SANITARY WARE SPECIFICATION SHEET

KB300 Color Select

KB300-00 Beige Color



KB300-01 Grey Color



KB300-05 White Granite Color



All color of the above is for the reference only.

Colors



Beige 00



Grey 01



White Granite 05

Note:

* All information of the above is for the reference only. No prior notice is made if any changes.