



Ka Shing Enterprise (H.K.) Ltd.

ROOM 1706 NEW TERRITORIES TSUEN WAN HO LIK CENTRE, 66A SHA TSUI ROAD
 Tel:26280661 Fax: 24902700
 Email: project@kashingehk.com
 Website: www.kashingehk.com

PROJECT		REF		REV	ITEM CODE	
LOCATION		DATE			PAGE	

SANITARY WARE SPECIFICATION SHEET

<p>Item Descriptions</p> <p>Dimensions</p> <p>Model</p> <p>Colour</p> <p>Materials</p> <p>Manufacturer</p> <p>Source</p> <p>Contact Tel/Fax</p> <p>E-mail</p> <p>Website</p>	<p>Koala Kare (USA) Horizontal surface-mounted polyethylene baby changing station with 304 brushed stainless steel finish veneery</p> <p>L912 x W539 x H527 mm</p> <p>KB300-05SS</p> <p>White Granite</p> <p>304 Brushed Stainless Steel</p> <p>Koala Kare (USA)</p> <p>Ka Shing Enterprises (H.K) Limited Mr. Ivan Lau / Mr. GilmanYuen</p> <p>(852) 2628-0661 / (852) 2490-2700 project@kashingehk.com www.kashingehk.com</p>	<p style="text-align: center;">Illustration/ Drawing</p> <p>Technical Drawing Dimensions:</p> <ul style="list-style-type: none"> Top View: 912mm (width), 539mm (depth) Side View: 711mm (width), 783mm (width) Height: 527mm (total), 686mm (to floor) Other dimensions: 406mm (lid width), 951mm (total height), 75mm, 70mm, 73mm, 101mm
<p>MATERIALS:</p> <p>Injection-molded polypropylene with Microban® antimicrobial additive embedded into the bed surface. Type 304 brushed stainless steel finish veneer. Reinforced steel-on-steel hinge mechanism and metal mounting chassis with mounting hardware included. Labeled usage instructions and safety messages in four languages. Optional Braille label available. Contoured changing surface area is 535 sq. in (3452 sq. cm) and comes complete with impervious TPU safety strap and solid stainless steel external bag hook. Dual cavity liner dispenser holds approximately 50 KB150-99 bed liners.</p> <p>This Baby Changing Station has been tested to support 200 lbs with minimal deflection. Please note: This product is designed for infants only, up to 3.5 years of age and weighing less than 50 lbs..</p> <p>OPERATION:</p> <p>Concealed pneumatic cylinder and metal mounting chassis provides controlled, slow opening and closing of bed. Polypropylene is easy to clean and resists odors and bacterial growth. Complies with ASTM static load performance requirements when properly installed. Internalliner dispenser with integrated spring tab dispensed one liner at a time..</p> <p>Warning: To ensure that the unit supports the intended loads, baby changing stations must be properly installed according to the manufacturer's instructions</p>		
<p style="text-align: center;">Colors</p> <div style="display: flex; justify-content: center; gap: 20px;"> <div style="text-align: center;"> Grey 01 </div> <div style="text-align: center;"> White Granite 05 </div> </div>		

Note:

* All information of the above is for the reference only. No prior notice is made if any changes.



KB300 Installation Instructions

Step 1:

- Inspect contents and remove changing station from the shipping container and check for any freight damage. If damage is found, please call Koala Kare Products' Customer Service at 888.733.3456.
- Identify the best location for installing the unit.

Fig. 1

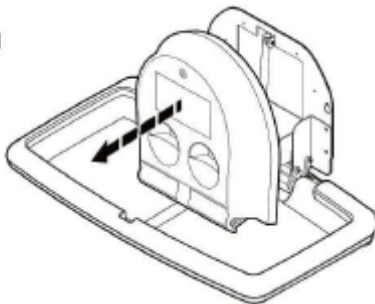

Step 2:

- Remove the bed and chassis from the box. Open the main unit by pulling up on the frame and remove the plastic liner dispenser. Set it to one side. **Fig. 1**
- Make sure you have taken into consideration the operating clearance of $9\frac{3}{8}$ " (238mm) on both sides of the exposed chassis and $21\frac{1}{8}$ " (537mm) from wall surface when open.

For Wood Stud Wall

- Measure from the floor $37\frac{7}{16}$ " (951mm) on stud center and mark the wall. The mounting holes are designed for 16" (406mm) stud centers. Ensure the locations you have marked for the mounting holes are level before drilling. **Fig. 2** Drill pilot holes for keyhole mounting using a $\frac{1}{8}$ " regular drill bit.
- If the wall has wooden studs that are not on 16" (406mm) centers, you will need to use toggles to secure one side of the unit. The other side should be secured to the stud using the screws provided. You must allow for space inside the wall for the toggles to turn. This will vary depending on the toggles used.

For Masonry or Tile over Stud Wall

- Use a $\frac{7}{32}$ " (5mm) masonry drill bit for the pilot hole until you hit the stud. Change bit to $\frac{1}{8}$ " (3mm) regular drill bit.

For Metal Stud or Concrete Block

- If the wall has metal studs or an underlying surface of concrete block, you will need to use toggles to secure one side of the unit. The other side should be secured to the stud using the screws provided. You must allow for space inside the wall for the toggles to turn. This will vary depending on the toggles used.

Fig. 2

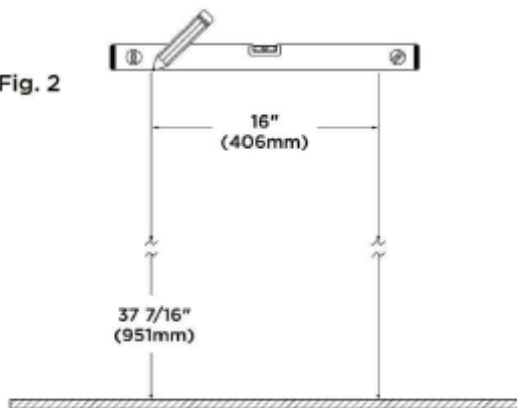

*Diagrams are not to scale.



KB300 Installation Instructions

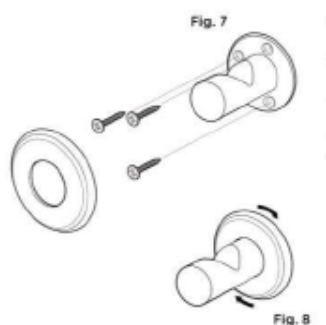
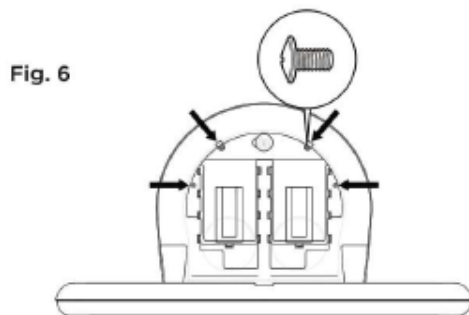
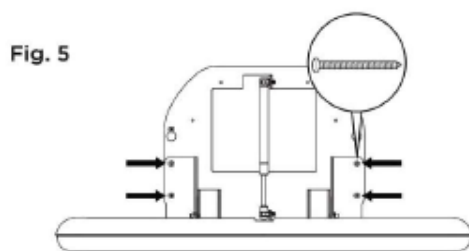
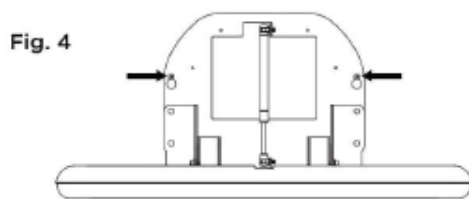
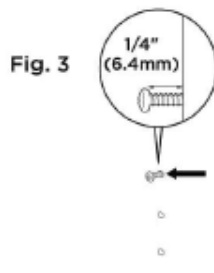

Fig. 8

Step 3:

- Mount bed and chassis by screwing two of the mounting screws into the pilot holes leaving 1/4" (6.4mm) exposed to allow keyhole slots to be easily mounted over the screw heads. **Fig. 3**
- Place chassis over screws. **Fig. 4**
- After securing the unit using the keyhole slots, verify that the unit is level. Tighten top two screws so that they are flush with the wall.
- Use the four lower holes as a guide to mark and drill pilot holes. Use remaining four screws and four washers to complete installation of bed and mounting bracket. Insert washers over lower four screws. **Fig. 5**
- All six screws and four washers must be properly mounted to the chassis.

Step 4:

- To install liner dispenser ensure liner dispenser is free from damage. Remove key, unlock, and open liner dispenser lid. This will expose liner dispenser mounting holes.
- Line up dispenser mounting holes onto chassis and secure with the four screws provided. **Fig. 6** Close and lock the liner dispenser door.

Step 5:

- Clean work area and inspect unit to ensure it opens and closes smoothly.

Step 6:

- To install the bag hook, measure up 44" (1118mm) from finished floor in the desired location and mark the wall.
- Position the bag hook on the wall so that the top of the mounting plate is level with the 44" (1118mm) mark.
- Position the bag hook over a wall stud for optimal strength.
- Mark then predrill the mounting holes. **Fig. 7**
- Use the provided screws to secure the bag hook in position, then take the escutcheon plate and screw it over the mounting plate to cover the mounting screws. **Fig. 8**

*Diagrams are not to scale.