



PROJECT		REF		REV	ITEM CODE	
LOCATION		DATE			PAGE	

SANITARY WARE SPECIFICATION SHEET

Item Descriptions	Koala Kare (USA) Horizontal surface mounted baby changing station; European Standards: EN 12221 Changing units for domestic use.	<p align="center">Illustration/ Drawing</p>
Dimensions	L1053 x W669 x H167 mm	
Model	KB310-SSWM	
Finish / Material	Satin finished / 304 Stainless Steel	
Manufacturer	Koala Kare (USA)	
Source	Ka Shing Enterprises (H.K) Limited Mr. Ivan Lau / Mr. GilmanYuen	
Contact Tel/Fax	(852) 2628-0661 / (852) 2490-2700	
E-mail	project@kashingehk.com	
Website	www.kashingehk.com	

KB310-SSWM Horizontal Stainless Steel Surface-Mounted

Wall-mounted, horizontal baby changing station that features one-piece, deep-drawn, uniform grain stainless steel exterior. This construction eliminates seams, sharp edges, and weld lines to form a modern aesthetic that helps upgrade the look of any washroom. Also available in a Black Matte finish (KB310-SSWM-MBLK).

Key product features include ADA and ASTM compliance, laser etched logo, and an easy to load and use dual-cavity dispenser for sanitary bed liners and diaper disposal bags. The KB310 comes with a wall-mounted, stainless steel bag hook to make accessing diaper bags easier and safer.

The polypropylene bed surface contains exclusive Microban® antimicrobial product protection, which reduces odor-causing bacteria between cleanings.



Colors

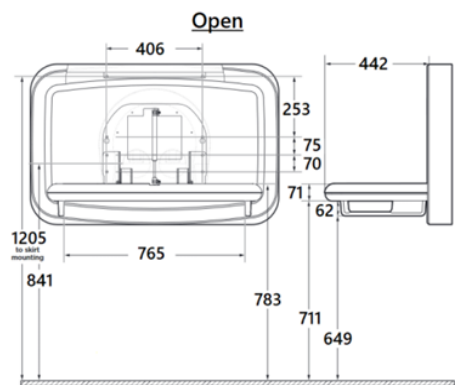
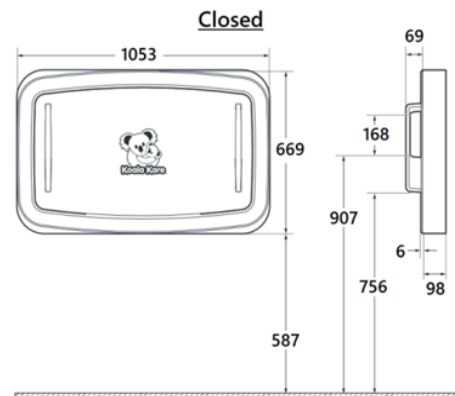

Note:

* All information of the above is for the reference only. No prior notice is made if any changes.

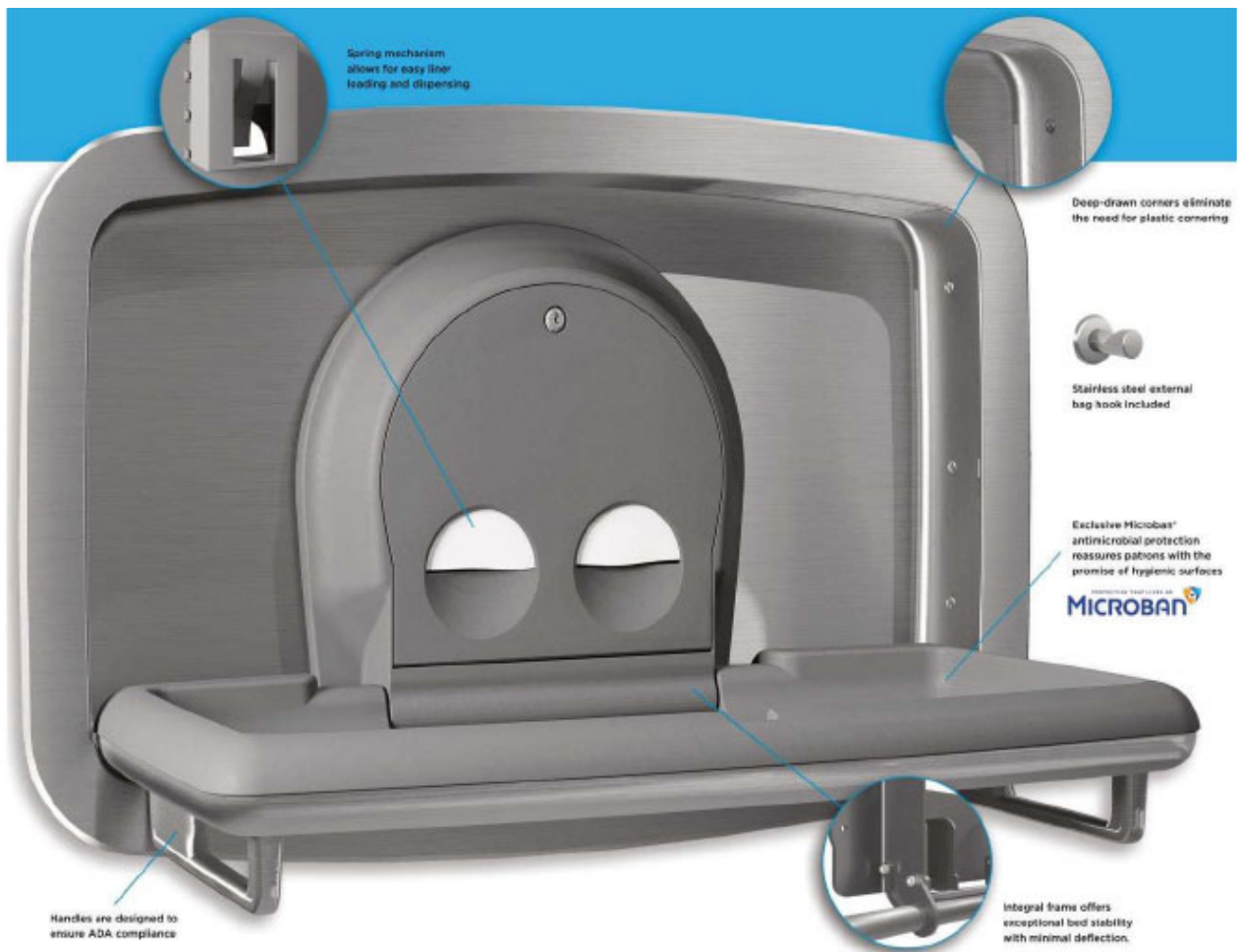

We've Reinvented the Baby Changing Station—Again.

Koala Kare combined our decades-long commitment to compliance with our passion for accommodating families to create our newest baby changing stations. Thanks to direct input from architects and end-users, we've developed our most innovative products ever.

Exclusive Craftsmanship

The KB310/KB311 line represents Koala's investment in unparalleled craftsmanship. The one-piece, deep-drawn, uniform grain stainless steel components eliminate seams, sharp edges and weld lines, and provide a modern visual aesthetic.

Thoughtful patron amenities enhance the end-user experience, and include a redesigned liner dispenser and a convenient bag hook for safely storing a diaper bag off the floor.

KB310/311 Specifications

- Fully compliant with ADA requirements. Meets ASTM and EN Safety Standards.
- Front panel and flange are one-piece deep-drawn seamless stainless steel with satin finish.
- No plastic covering or visible plastic on the front of the unit and no adhesive labels applied to the front panel.
- Unit has minimal deflection from 90 degrees. Has been tested to support 300lbs (137kg).
- External bag hook is a solid stainless steel rod with satin finish.
- Dual-cavity liner dispenser has integral spring tab that dispenses one liner at a time. Equipped with tumbler lock, keyed alike for Bobrick restroom accessories.

- Bed surface manufactured with Microban® antimicrobial product protection and the efficacy of additives has been confirmed by ISO 22196 testing.

Product Dimensions

- Rough wall opening:
KB310-SSRE Horizontal:
37 1/16" x 21 5/8"
(941mm x 549mm)
KB311-SSRE Vertical:
21 1/2" x 36 3/4"
(546mm x 934mm)

Please note: This product is designed for infants only, up to 3.5 years of age and weighing less than 50 lbs (23kg).

ADA Compliance

The new units have been designed to meet a comprehensive range of global accessibility requirements



Forward Reach

When closed, the handles are below 48" (1219mm) and guide patrons to operate the unit with less than 5lbs of force. The internal liner dispenser will be below 44" (1117mm).

ADAS/TAS/ICC 2009/2017 308.2.1



Protruding Objects

Both the leading edge of the surface mounted unit and the handles on the horizontal unit, when open, fall below 27" (685mm), allowing for cane detection. The recessed unit when closed does not protrude more than 4" (101mm).

ADAS/TAS/ICC 2009/2017 307.2

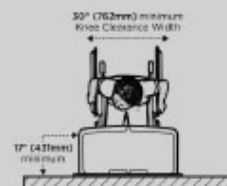

Knee and Toe Clearance

For wheelchair access, the space between the handles provides more than 30" (762mm) of width and the under side of the unit is over 27" (685mm) above the finished floor. The open unit provides more than 17" (431mm) of depth for toe clearance.

ADAS/TAS/ICC 2009/2017 306



KB310-SSWM Installation Instructions

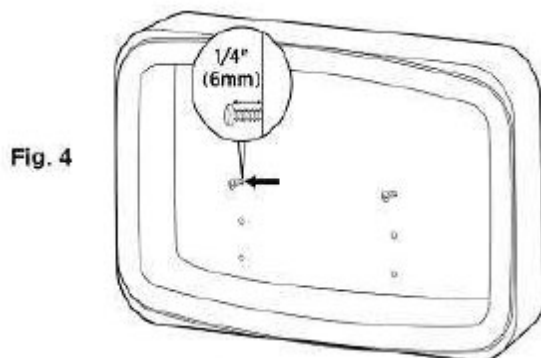
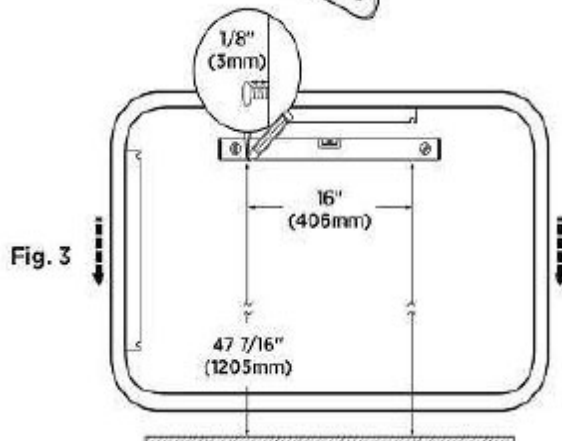
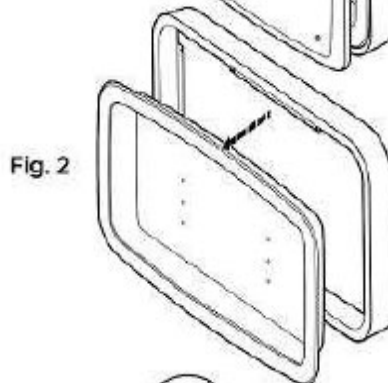
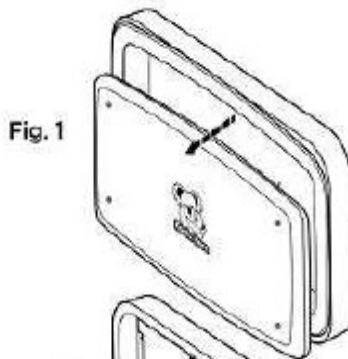

*Diagrams are not to scale.

Step 1:

- Be sure to wear safety gloves to protect your hands from the products exposed metal edge.
- Remove the handles and bag hook from the packaging and set to one side.

Step 2:

- Remove the main unit from the flange by lifting it out and set to one side, face down on a protected flat surface. **Fig. 1**
- Lift the flange out of the skirt and set to one side. **Fig. 2**

Step 3:

- Measure up the wall $47 \frac{7}{16}$ " (1205mm) and mark the desired mounting location on wall stud center. **Fig. 3**
- Measure across 16" (406mm) and use a level to mark for the second mounting location. The skirt has two hangers set on 16" (406mm) centers for easy installation.
- Predrill and screw in the provided mounting screws, make sure to leave $\frac{1}{8}$ " (3mm) of the thread exposed.
- Position the hangers over the screws and hang the skirt. Make sure to check it is level before securing the mounting screws.

Step 4:

- Take the flange and position it inside the skirt. Make sure the mounting holes are towards the floor. Flange should be centered inside the skirt.
- Use the mounting holes to mark and predrill for the mounting screws. Screw in the top two screws, make sure you leave $\frac{1}{4}$ " (6mm) of thread exposed for hanging the main unit. **Fig. 4**



KB310-SSWM Installation Instructions

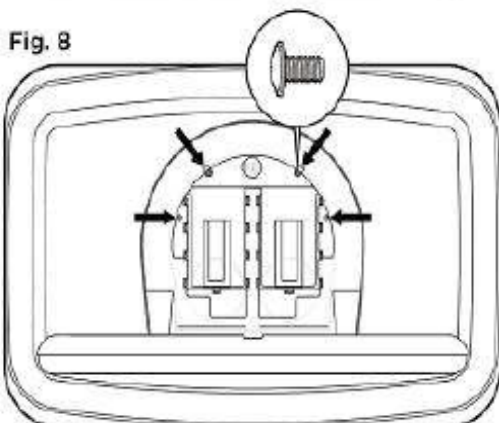
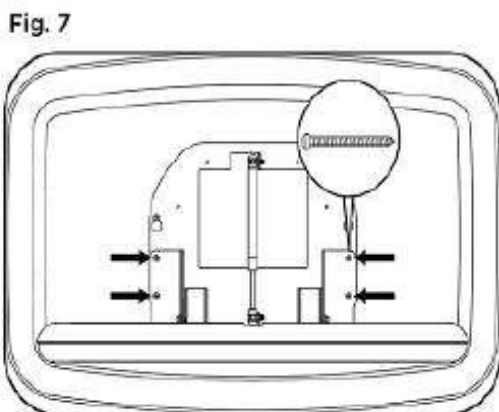
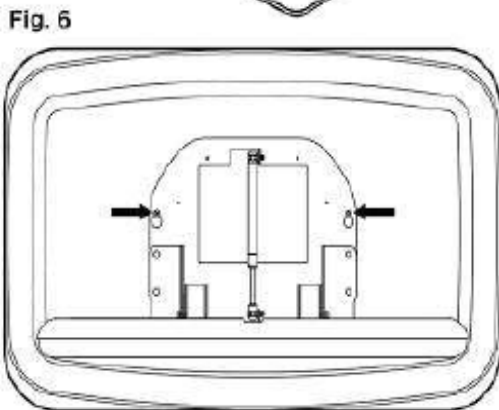
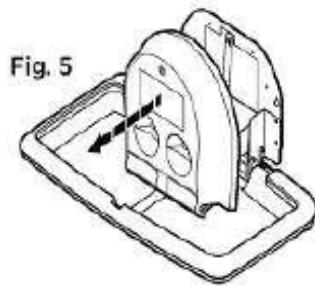

Step 5:



- Open the main unit by pulling up on the frame and remove the plastic liner dispenser. Set it to one side.

Fig. 5

- Lift the unit into the flange locating the key holed mounting holes over the mounting screws. **Fig. 6**
This may be easier with the assistance of a second person.

Step 6:

- Secure the unit through the remaining mounting holes with the provided mounting screws. **Fig. 7**
- Tighten the upper mounting screws.

Step 7:

- With the unit open take the liner dispenser and position it over the exposed metal frame in the center of the flange.
- Use the provided key to open the liner dispenser. This will provide access to the four mounting holes.
- Use the provided hardware to secure the liner dispenser to the metal frame. **Fig. 8**
- Lock the liner dispenser and close the unit.

*Diagrams are not to scale.

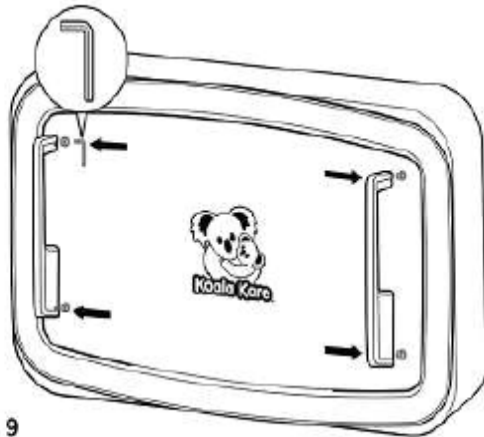

Fig. 9

Step 8:

- Take one of the provided handles and position it over the handle mounting studs, so that the open portion is toward the top of the unit.
- Use provided Allen wrench to tighten the set screws in the handles, securing it to the handle mounting studs. **Fig. 9**
- Repeat for the opposite handle.

Step 9:

- Test the unit by opening and closing multiple times, ensuring it opens and closes smoothly.
- Remove protective film from the surface of the unit.

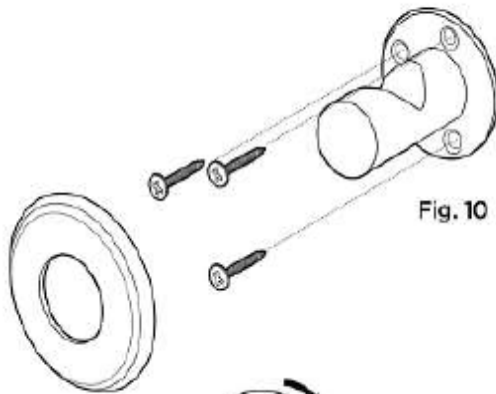

Fig. 10



Fig. 11

Step 10:

- To install the bag hook, measure up 44" from finished floor in the desired location and mark the wall.
- Position the bag hook on the wall so that the top of the mounting plate is level with the 44" mark.
- Position the bag hook over a wall stud for optimal strength.
- Mark then predrill the mounting holes. **Fig. 10**
- Use the provided screws to secure the bag hook in position, then take the escutcheon plate and screw it over the mounting plate to cover the mounting screws. **Fig. 11**

*Diagrams are not to scale.