

SANITARY WARE SPECIFICATION SHEET

Model: WDU-1ASUK

Descriptions: McAlpine (UK) "Perfect Grind®" 1½" 40mm 180° Dual swivel anti-jam impellers prevent jamming waste disposal units

Dimensions: Refer to drawing

Material : Stainless steel

Manufacturer: McAlpine (UK)

Finish : Satin

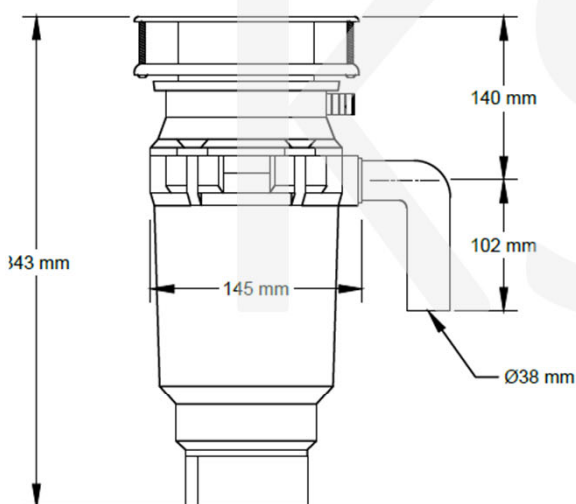
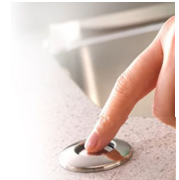

* All information of the above is for the reference only. No prior notice is made if any changes.



Ka Shing Enterprise (H.K.) Ltd.

ROOM 1706 NEW TERRITORIES TSUEN WAN HO LIK CENTRE, 66A SHA TSUI ROAD
Tel:26280661 Fax: 24902700
Email: project@kashingehk.com
Website: www.kashingehk.com

Ivan / Horace 26280661

E/ project@kashingehk.com

W/ <https://www.kashingehk.com/>

McALPINE

CE

Perfect Grind[®] Can Grind Them All!

You shouldn't have to ask if your waste disposer can handle your food scraps!



Chicken Bones



Banana Peels



Melon Rinds



Nut Shells



Vegetable Scraps



Meat Scraps



Corn on the Cob



Fruit Pits



Apple Core



Coffee Grounds

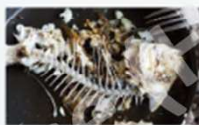

Fish Bones



Egg Shells

High Torque Means Virtually Jam-Free Versatility!

McAlpine's Perfect Grind disposers have been designed to handle a large variety of food scraps.

Available in 4 models:

Code	HP	Noise Level
WDU-1ASUK	1/2 HP	51-53dBA
WDU-2ASUK	2/3 HP	51-53dBA
WDU-3ASUK	3/4 HP	56.4dBA
WDU-4ASUK	1 1/4 HP	56-57dBA



Perfect Grinding System

Perfect Grind[®] System can efficiently grind the toughest bones faster and finer than other brands and is safe for any properly sized septic system. Wear resistant and corrosion proof.

- Stainless steel, high precision, high speed dynamic balanced grinding turntable
- Stainless steel, dual swivel anti-jam impellers prevent jamming
- Stainless steel grinding rings
- Specially designed large opening, round holes and arch cutters



Corrosion Proof Grinding Chamber

Grinding chamber is constructed with the proven durability of glass filled nylon for lasting performance and is treated with BioGuard antimicrobial odour protection.

Accessories



BFKIT-1UK Batch Feed Kit

For converting continuous feed models to batch feed allowing the disposal unit cover to be used as an on/off switch.



AS-UK Air Switch Adaptor

For converting WDU1-UK unit from wall switch to air switch operation.

McALPINE
Plumbing Products

Perfect Grind® Waste Disposal Units

An environmentally sound solution to the growing problem of food waste.

- 25% more torque than other brands provides more grinding power
- Unique permanent magnet motor produces higher RPM (revolutions per minute) than AC (alternating current) induction motors
- Corrosion proof cast stainless steel impellers on all models
- 180° dual swivel anti-jam impellers prevent jamming
- High efficiency performance saves time, water and energy
- Motor incorporates sound eliminating insulation technology for quiet operation
- BioGuard antimicrobial eliminates bacteria and odours
- Power cord included
- Supplied with 90° Bend x 1½" BSP thread for connection to trap



Perfect Grind®
By McAlpine Plumbing



CE

CONTINUOUS FEED 1/2 HP FOOD WASTE DISPOSER

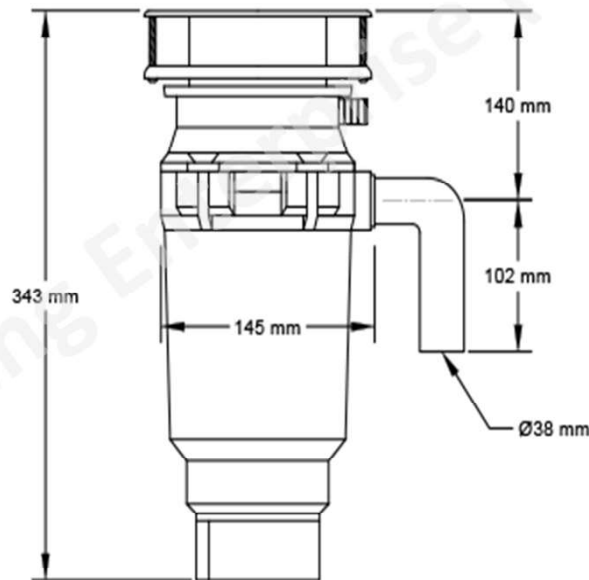

This model offers the following features:

- Permanent Magnet High RPM Means High Torque and Less Jams
- Bio-guard Antimicrobial Protection
- Removable Splash Guard
- Stainless Steel Turntable and Grind Rings (Compared to Competitor's Cold-Rolled or Galvanized Steel)
- Factory Installed Power Cord with Plug
- Safe for Properly Sized Septic Tanks
- 3-Bolt Mounting System

SPECIFICATIONS

HP	1/2
Motor Type	Permanent Magnet
Feed	Continuous
Volts	220V
Frequency	50/60Hz
Motor Speed	2500RPM
Hopper Capacity	857 ml
Balance Level	G0.4
Turntable	Stainless Steel
Grind Rings	Stainless Steel
Sink Flange	Stainless Steel
Basket Strainer	Stainless Steel
Drain Elbow	ABS
Bearings	Permanently Lubricated, Sleeve Type
Manual Reset Protector	Protection for Overload and Temp.
Shipping Weight	4.81 kg
Pallet Quantity	144pcs



FOOD WASTE DISPOSER INSTRUCTION MANUAL



See insert for specific information about your new disposer

- NOTE:** This Food Waste Disposer has been designed to operate on 220-240 Volt, 50 Hz exclusively. Using any other voltage or Hz adversely affects performance
- IMPORTANT:** Read all instructions thoroughly. Keep this guide for future reference.
- CAUTION:** Be sure to review SAFETY INSTRUCTIONS FIRST PERTAINING TO A RISK OF FIRE, ELECTRICAL SHOCK OR INJURY TO PERSONS before using disposer.

Record important disposer information here

Model Number*

Serial Number*

*Above information appears on the label affixed to bottom of the disposer. For your convenience, write down the model and serial number prior to installation. **Proof of purchase is required for Warranty. Staple receipt or proof of purchase to this manual for easy reference.**
Warranty is non-transferable.

IMPORTANT SAFETY INSTRUCTIONS

INSTRUCTIONS PERTAINING TO A RISK OF FIRE, ELECTRIC SHOCK OR INJURY TO PERSONS. SAVE THESE INSTRUCTIONS.

WARNING – When using electrical appliances, basic precautions should always be followed, including the following:

1. Read all instructions before using the appliance.
2. To reduce the risk of injury, close supervision is necessary when an appliance is used near children.
3. Do not put fingers or hands into a waste disposer.
4. Turn the power switch to the off position before attempting to clear a jam or remove an object from the disposer.
5. When attempting to loosen a jam in a waste disposer, use a long wooden object such as a wooden spoon or the wooden handle of a broom or mop.
6. When attempting to remove objects from a waste disposer use long-handled tongs or pliers. If the disposer is magnetically actuated, non-magnetic tools should be used.
7. To reduce the risk of injury by materials that may be expelled by a waste disposer, do not put the following into a disposer: clam or oyster shells; caustic drain cleaners or similar products; glass, china or plastic; large whole bones; metal, such as bottle caps, tin cans, aluminum foil or utensils; hot grease or other hot liquids; whole corn-husks.
8. When not operating a disposer, leave the stopper in place to reduce the risk of objects falling into the disposer.
9. DO NOT operate disposer unless splash guard is in place.
10. For proper grounding instructions see the ELECTRICAL CONNECTIONS portion of this manual.

The electrical outlet to which this appliance is connected must be controlled by a switch.

1. REMOVAL OF OLD UNIT

TYPICAL INSTRUCTIONS, YOUR MODEL MAY VARY.

Before starting this step, turn off electrical power at the circuit breaker or fuse box. Unplug disposer.

If your old mount is the same type as the mount on your new disposer, just reverse the assembly instructions found in section 3. If your new mount system is different, follow these instructions:

- A. Have a container available to catch any excess water / waste from current disposer.
- B. Use a pipe wrench to disconnect drain line where it attaches to disposer discharge elbow (see 1A).
- C. Remove disposer from sink flange by turning mount ring to the left clockwise (see 1B). If you are unable to turn the mount ring, tap on one of the extensions from the ring with a hammer. Some mounting systems have tubular extensions. Inserting a screwdriver into one tube will provide additional leverage for turning the mount ring (see 1B). Some disposers may require the removal or loosening of nuts from the mount screws (see 1C). Some disposers may require the removal of a clamp.

Caution: Be sure to support the disposer while performing this step or it may fall when the mounting ring is disconnected from the mounting assembly.

- D. To remove remaining mount system from the sink, loosen mount screws, push mount ring up. Under it is the snap ring. Use screwdriver to pop off ring (see 1D). Remove mount ring, protector ring and gasket from sink flange. Some mounts will require the unscrewing of a large ring holding the sink flange in place. Pull sink flange up through sink and clean off old putty from sink.
- E. Ensure that sink is clean and thoroughly dry.

IMPORTANT: This is a good time to clean out the trap and drain lines by running a drain auger or plumber's snake before installing your new disposer.

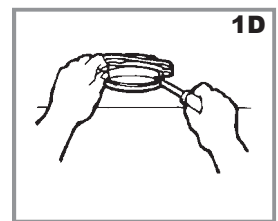
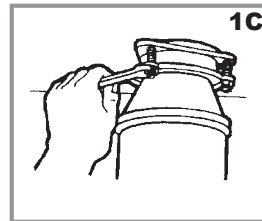
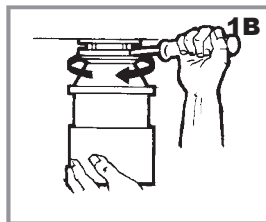
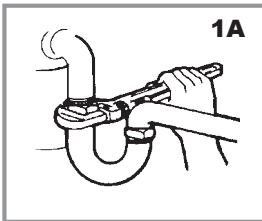

2. DISHWASHER CONNECTION

IF DISHWASHER IS NOT TO BE CONNECTED GO ON TO SECTION 3.





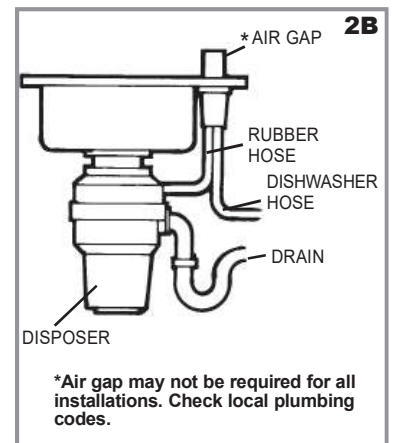
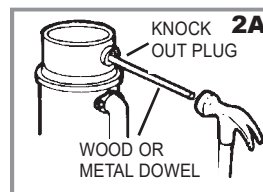

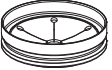

If you are utilizing a dishwasher, complete the following procedure.

- A. Using a blunt instrument (steel punch or wooden dowel), knock out entire plug (see 2A). Do not use a screwdriver or sharp instrument. (When knockout plug falls into disposer, you may remove it or grind it up when the disposer is used. This will not damage the disposer in any way, but may take some time to grind).
- B. Connect dishwasher hose (see 2B) using hose clamp. Make sure all plumbing connections are tight and in accordance with all plumbing codes and ordinances. Run water and check for leaks.



3. INSTALLATION OF MOUNTING ASSEMBLY

READ CAREFULLY AND COMPLETELY BEFORE STARTING

- A  STOPPER
- B  REMOVABLE SPLASH GUARD
- C  SINK FLANGE
- D  FIBER GASKET
- E  SUPPORT FLANGE
- F  UPPER MOUNT RING
- G  MOUNT SCREWS
- H  RETAINER RING
- I  CUSHION RING*
- J  LOWER MOUNT RING*

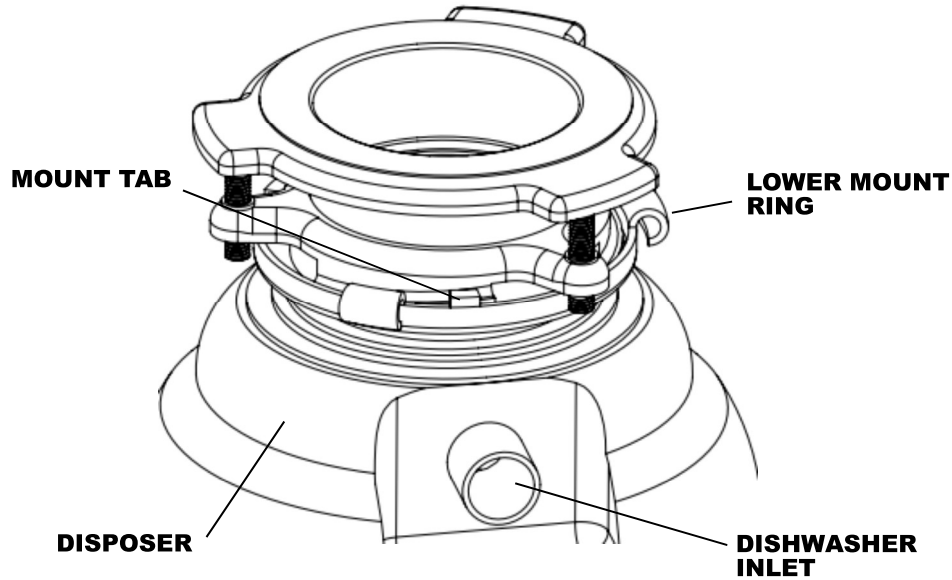

NOTE: Cushion Ring included between the Upper Mount Ring and Lower Mounting Ring.

* Part not disengaged during disposer installation.

NOTE: As the mounting assembly is properly assembled at the factory, please pay close attention to the order of the mounting system parts.

- a. **The Cushion Ring and the Lower Mount Ring will remain attached to the disposer during installation.** Take apart the other parts of the mounting assembly by rotating Lower Mount Ring (J) clockwise until the Lower Mount Ring Tabs slide off from the Upper Mount Ring ramp. This allows you to pull the Sink Flange up and out of the remaining Lower Mount Assembly. Note the order of these parts as they are arranged in the required order. Unscrew the 3 Mount Screws until the Upper Mount Ring can be moved to the top of the Support Flange. Remove the Retainer Ring with a screw driver.
- b. Keep the remaining parts placed together in the order they were removed. Before you connect the disposer to the mount assembly under the sink, make sure the Lower Mount Ring is in place and the black Cushion Ring is still engaged properly to the top of the hopper. (Do Not Remove It)

INSTALLATION OF MOUNTING ASSEMBLY (CONTINUED)

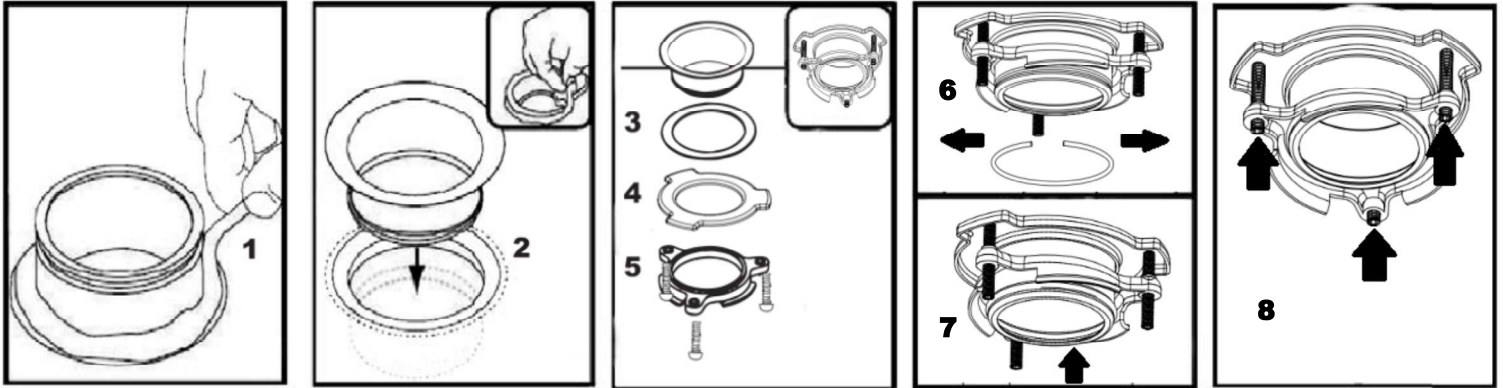

c. Be sure the sink is clean. Load the underside rim of the sink flange with a suitable sealant (Recommended: - MACXSEAL) (1). From the top of the sink, push the sink flange down against the sink opening to make a good seal (2). **DO NOT MOVE OR ROTATE** the sink flange once it has been seated or the seal may be broken.

d. **Place a heavy object, such as the disposer (use a towel to prevent sink scratching) on top of the Sink Flange to hold it down.**

e. Take the remaining portion of the mount assembly, that was put aside. From under the sink insert the Fiber Gasket (3), then the Support Flange (4), and then the Upper Mount Ring (5).

f. Hold the three parts in place while attaching the Retainer Ring (6) by pulling it apart and having it snap within the groove of the sink flange (7).

g. Tighten the three Mount Screws evenly and firmly against the Support Flange (8). **Do not over tighten.**

h. Wipe of any excess sealant.

i. Attach disposer onto the Upper Mount Ring by aligning the three mount tabs on the Lower Mount Ring with the slide-up Ramps on the Upper Mount Ring and rotating counter clockwise. See Below.

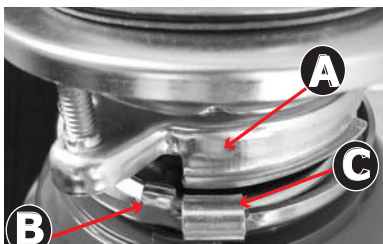
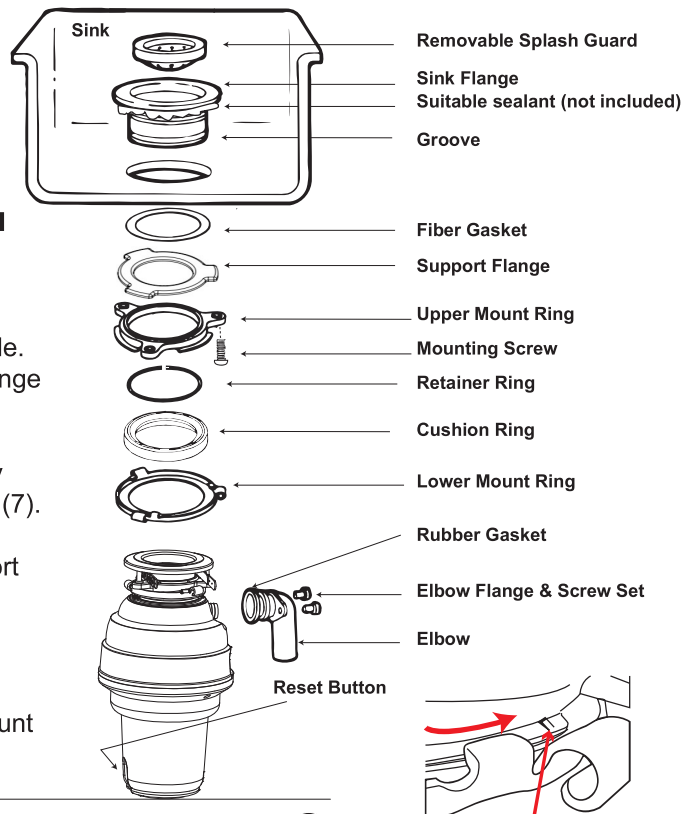

The lower mounting ring (which is part of the disposer) has 3 tabs that grab the mounting ring ramp. (A) points to the Upper Mount Ring. (B) is the tab that slides up onto the "Ramp". (C) is the "Ear" that is used to help rotate the Lower Mount Ring. Use a screwdriver for leverage if needed.

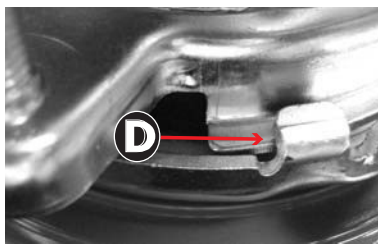

Lift and turn the Lower Mount Ring counter clockwise until all three mount tabs lock over the Ridges (F) on the slide-up Ramps (D) of the Upper Mount Ring.

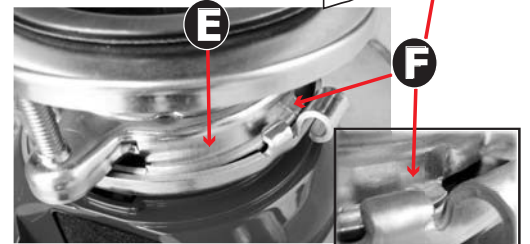

As the Lower Mount Ring is turned counter clockwise each tab slides up onto the Upper Mount Ring Ramp (E) and locks in position over the Ridges (F).

Use a screwdriver or hammer for leverage if needed.

If a disposer needs to be removed, tapping on the Ear clockwise with a hammer will easily loosen the Lower Mount Ring.

4. ELECTRICAL CONNECTIONS

- A. Connect disposer to appropriate household voltage only.

The electrical outlet to which this appliance is connected must be controlled by a switch.

WARNING: IMPROPER CONNECTION OF THE EQUIPMENT-GROUNDING CONDUCTOR CAN RESULT IN A RISK OF ELECTRIC SHOCK. CHECK WITH A QUALIFIED ELECTRICIAN OR SERVICEMAN IF YOU ARE IN DOUBT AS TO WHETHER THE APPLIANCE IS PROPERLY GROUNDED. DO NOT MODIFY THE PLUG PROVIDED WITH THE APPLIANCE IF IT WILL NOT FIT THE OUTLET. HAVE A PROPER OUTLET INSTALLED BY A QUALIFIED ELECTRICIAN.

GROUNDING INSTRUCTIONS

FOR WASTE DISPOSERS EQUIPPED WITH A GROUNDED PLUG-IN POWER CORD.

- B. This appliance must be grounded. In the event of a malfunction or breakdown, grounding provides a path of least resistance for electric current to reduce the risk of electric shock. This appliance is equipped with a cord having an equipment-grounding conductor and

a grounding plug. The plug must be plugged into an appropriate outlet that is properly installed and grounded in accordance with all local codes and ordinances. If the supply cord is damaged it must be replaced by the manufacturer, its service agent or similarly qualified person in order to avoid a hazard. **Removing an attached power cord or plug voids the warranty.**

5. ATTACHING DISCHARGE ELBOW

- A. Connect waste elbow to the disposer (see 5A), proceed to step 6 and then connect bottom of the elbow by tightening the slip nut (see 5B). If using a straight pipe, it must have a lip similar to the one on the elbow. Remove the gasket from the elbow and install it on the straight pipe with the flat end of the gasket facing toward the disposer discharge opening.
- B. If you are connecting to a dishwasher, return to section 2B. If not, make sure all plumbing connections are tight and in accordance with all plumbing codes and ordinances. Run water and check for leaks.

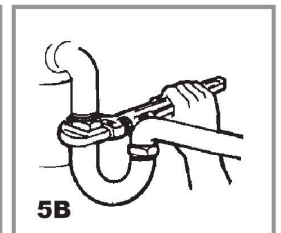
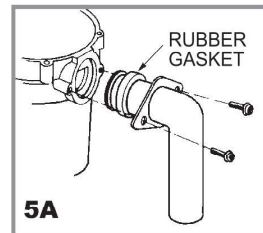

7. OPERATING INSTRUCTIONS

The Anti-Jam Swivel Impellers make a clicking sound as they initially swing into place. This indicates normal operation.

- A. Remove sink stopper. Turn on a medium flow of cold water.
- B. Turn switch to ON position; your motor is turning at full speed and ready to use.
- C. Scrape in food waste. Down the drain go table scraps, peelings, rinds, seeds, pits, small bones and coffee grounds. To speed up food waste disposal, cut or break up large bones, rinds and cobs. Large bones and fibrous waste require considerable grinding time
- D. Before turning disposer off, let water and disposer run for approximately 15 seconds after shredding or grinding stops. This assures that all waste is thoroughly flushed through trap and drain.
- E. It is not recommended to use hot water while running disposer. Cold water will keep waste and fats solid so disposer can flush away particles.

TIPS FOR SUCCESSFUL OPERATION

- A. Be sure disposer is empty before using your dishwasher so it may drain properly.
- B. You may want to leave the stopper in the sink drain when not in use to prevent utensils and foreign objects from falling into the disposer.
- C. Your disposer is ruggedly built to give you many years of trouble free service. It will handle all normal food wastes, but it will NOT grind or dispose of such items as plastic, tin cans, bottle caps, glass, china, leather, cloth, rubber, string, clam and oyster shells, aluminum foil or feathers.

8. CLEANING AND MAINTENANCE

DO NOT ATTEMPT TO LUBRICATE YOUR DISPOSER!

The motor is permanently lubricated. The disposer is self cleaning and scours its internal parts with each use.

NEVER put lye or chemical drain cleaners into the disposer, as they cause serious corrosion of metal parts. If used, resulting damage can be easily detected and all

warranties are void. Mineral deposits from your water can form on the stainless steel turntable, giving the appearance of rust. DO NOT BE ALARMED, the stainless steel turntables used will not corrode.

9. TROUBLESHOOTING

Before seeking repair or replacement, we recommend that you review the following:

LOUD NOISES: (Other than those during grinding of small bones and fruit pits): These are usually caused by accidental entry of a spoon, bottle cap or other foreign object. To correct this, turn off electrical switch and water. After disposer has stopped, remove splash guard, remove object with long handled tongs, and replace splash guard.

UNIT DOES NOT START: Unplug power cord or turn either the wall switch or breaker box switch to "OFF" position, depending on your model and wiring configuration. Remove stopper and/or splash guard. Check to see if turntable will rotate freely using a wooden broom handle. If turntable rotates freely, replace splash guard and check reset button to see if it has been tripped. Reset button is red and located on the front of the disposer. Push button in until it clicks and remains depressed.

If reset button has not been tripped, check for shorted or broken wire connecting to disposer. Check electrical power switch, fuse box or circuit breaker. If wiring and electrical components are intact, the unit may have internal problems that require service or replacement.

IF TURNTABLE DOES NOT ROTATE FREELY: Turn off disposer, then check for any foreign object lodged between the turntable and grind ring. Dislodge object by rotating table with a wooden broom handle (see 9A) and remove object. If no foreign object is present, there may be internal problems.

1. Improper Seating of sink flange (gasket centering, Sealant, or tightening).
2. Support ring not tightened properly.
3. Defective or improperly installed cushion mount.

If unit leaks at the waste elbow, leak may be due to improper tightening of elbow flange screws.

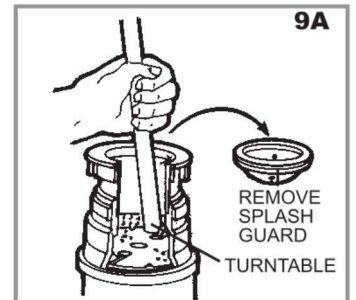

10. Disposer Air Switch Assembly (built-in Air Switch) Instructions

Disposer Air Switch Assembly is supplied in three basic parts:

The Actuator which consists of:

1. Actuator Button
2. Actuator Nut
3. Actuator Outlet (Black Threaded portion)

The Air Switch Sensor is installed into disposer. Only the air tube Nozzle is visible from the outside of the disposer.

Air Tube Assembly which consists of:

4. Air Tube - Clear or Black
5. Sensor Inlet



Installation and Operating Instructions:

- A. Drill a hole of 33mm to 35mm into the sink or countertop where the Actuator Button (#1) is to be placed.
- B. Insert from the top, the Actuator Outlet through the drilled hole.
- C. Firmly connect Air Tube (#4), one side to Actuator Outlet (#3) and one side to Sensor Inlet (#5).
- D. Plug Disposer Power Cord (#6) into main electrical service.
- E. To turn on disposer, press Actuator Button (#1). To turn off, press Actuator Button again.

Disabling the Air Switch:

The air switch can be disabled if wall switch operation is preferred. The disposer is shipped with the switch in the "off" position.

1. Push one end of the PVC tubing provided onto the spout of the push button bellows.
2. Take the other end of the air tube and firmly push it over the spout of the air switch, which is located on the underside of the waste disposer.
3. Depress the air switch one time until you hear the switch "click". Remove and discard the push button bellows and PVC tubing. The disposer may now be activated by a wall switch.