

SANITARY WARE SPECIFICATION SHEET

Model: CP0016HCSB-I

Descriptions: Mediclinics (Spain) horizontal surface-mounted baby changing station made of polypropylene and with AISI 304 stainless steel exterior, matte black finish with built-in antibacterial additive and an ionizer ("Ion Hygienic" technology) that eliminate microorganisms such as viruses, bacteria, fungi, etc. Loads of 50lbs with EN 12221-1 Registration No.HU21RUDZ 001

Dimensions: L860 x W100 (closed) / 570 (open) x H480 mm Material : Polyethylene and Stainless Steel
 Manufacturer: Mediclinics, S.A. (Spain) Finish : Matte Black Finish

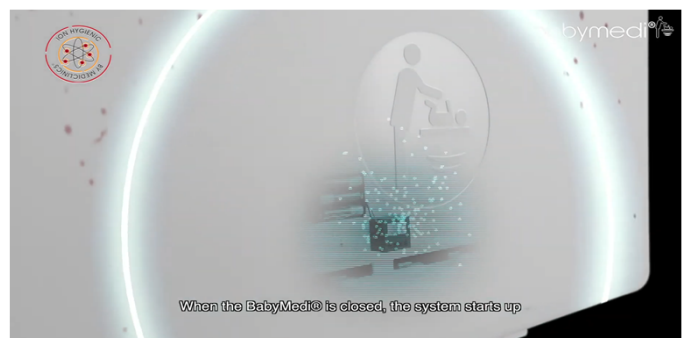
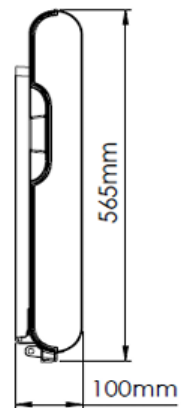
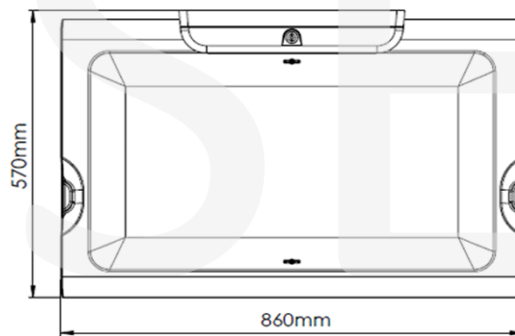
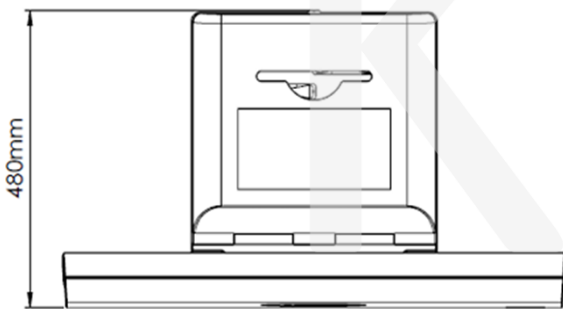

* All information of the above is for the reference only. No prior notice is made if any changes.



Ka Shing Enterprise (H.K.) Ltd.

ROOM 1706 NEW TERRITORIES TSUEN WAN HO LIK CENTRE, 66A SHA TSUI ROAD
 Tel:26280661 Fax: 24902700
 Email: project@kashingehk.com
 Website: www.kashingehk.com

Ivan / Horace 26280661

E/ project@kashingehk.com

W/ <https://www.kashingehk.com/>

Components and materials

- CP0016H-I: surface-mounted baby changing station made of polypropylene in white finish with ionizer.
- CP0016HCSB-I: surface-mounted baby changing station made of polypropylene and with a stainless steel AISI 304 exterior, in matte black finish with ionizer.
- CP0016HCS-I: surface-mounted baby changing station made of polypropylene and with a stainless steel AISI 304 exterior, in satin finish with ionizer.
- BED: with a 1,900 cm² contoured changing surface area is made of polypropylene in white finish with Biocote® antimicrobial additive embedded into its own surface, promoting an easy cleaning and reducing the growth of odor causing and staining microbes.
- LINER DISPENSER: with lock is made of polypropylene and holds approximately 80 bed liners, minimizing operator refills and discouraging potential vandalism.
- OPEN/CLOSE MECHANISM: concealed from the user's view, it consists of a pair of reinforced hinges and a pneumatic cylinder, ensuring high durability and a smooth opening and closing of the baby changing station.
- MOUNTING CHASSIS: made of steel with a cathoporesis treatment. The corresponding mounting hardware is supplied, making very easy the installation of the unit to the wall.
- FRONTAL CHASSIS: (CP0016HCS and CP0016HCSB) made of one-piece AISI 304 stainless steel, 0.8 mm thick, fixed to the bottom of the bed by means of 4 bolts and 4 nuts, always concealed from the user's view, without joints or edges to ensure the user's safety, a better cleaning and an easy blending with other satin-finish accessories in the washroom.
- IONIZER: neutralizes virus and bacteria from the baby changing station surfaces through negative ions (anions), making the BabyMedy more hygienic and healthier. Our ionizer has been tested and approved by TÜV Rheinland (Test Report number 60329708-001).

General Description

- Surface-mounted baby changing stations made of bacterial-resistant polypropylene and with stainless steel AISI 304 exterior (CP0016HCS and CP0016HCSB).
- BabyMedi® changing stations offer a very high level of safety and cleanliness being the ideal solution for public spaces such as shopping centers, airports, public buildings, childcare centres, etc. Models suitable for high traffic facilities with high strength and durability.
- Their trendy and stylish design, allow these baby changing stations to blend into any space perfectly.
- Biocote® antimicrobial additive, based on ion silver technology, is embedded into its own surface, promoting an easy cleaning and reducing the growth of odor causing and staining microbes.
- Ionizer ("Ion Hygienic" technology) that neutralizes virus and bacteria thanks to the negatively charged particles (anions) it emits, helping to maintain the baby changing station free of these harmful microorganisms for the baby health. **The effectiveness of the ionizer, against virus and bacteria, has been tested and approved by TÜV Rheinland (Microbiological Test Report number 60329708-001).**
- BabyMedi® baby changing stations are supplied (inside the packing box) with child protection straps made of nylon.
- A pair of bag hooks (one at the right side and the other one at the left) help to keep personal belongings close and at hand.
- BabyMedi® units fully comply with the EN 12221-1 and EN 12221-2 standards that require baby changing stations be able to support a 50 Kg static load test during one hour. Moreover, units tested in our own laboratories have withstood loads over 100 kg.

Technical Specifications

Dimensions	<i>L:860 x W:100 (closed)/ 570 (open) x H:480 mm</i>
Weight (empty)	<i>12.4 Kg (CP0016H-I) 16.0 Kg (CP0016HCS-I & HCSB-I)</i>
Liner dispenser capacity	<i>80 units</i>
Recommended installation height	<i>800 mm at lowest point</i>
Recommended installation height (handicapped)	<i>700 mm at lowest point</i>

OPERATION

Open the BabyMedi® baby changing station. Place the baby in the centre of the bed and change your baby's diapers. Close the BabyMedi® station.

Under no circumstance should the baby be left unattended at any time on top of the baby changing station in order to avoid injury from falling or slipping.

Type 1 baby changing station with the purpose to be used from the children birth up to the age of 12 months and up to a weight of 11 Kg, in accordance with the manufacturer's instructions for use.



Ka Shing Enterprise (H.K.) Ltd.

ROOM 1706 NEW TERRITORIES TSUEN WAN HO LIK CENTRE, 66A SHA TSUI ROAD
Tel:26280661 Fax: 24902700
Email: project@kashingehk.com
Website: www.kashingehk.com

Ivan / Horace 26280661

E/ project@kashingehk.com

W/ <https://www.kashingehk.com/>

MOUNTING

Fix the mounting chassis on the wall using the provided screws through the mounting chassis holes (points indicated by an "S" in the figure below) and **always following, step by step, the detailed instructions contained in the "Installation and safety instructions manual"**, provided with the unit.

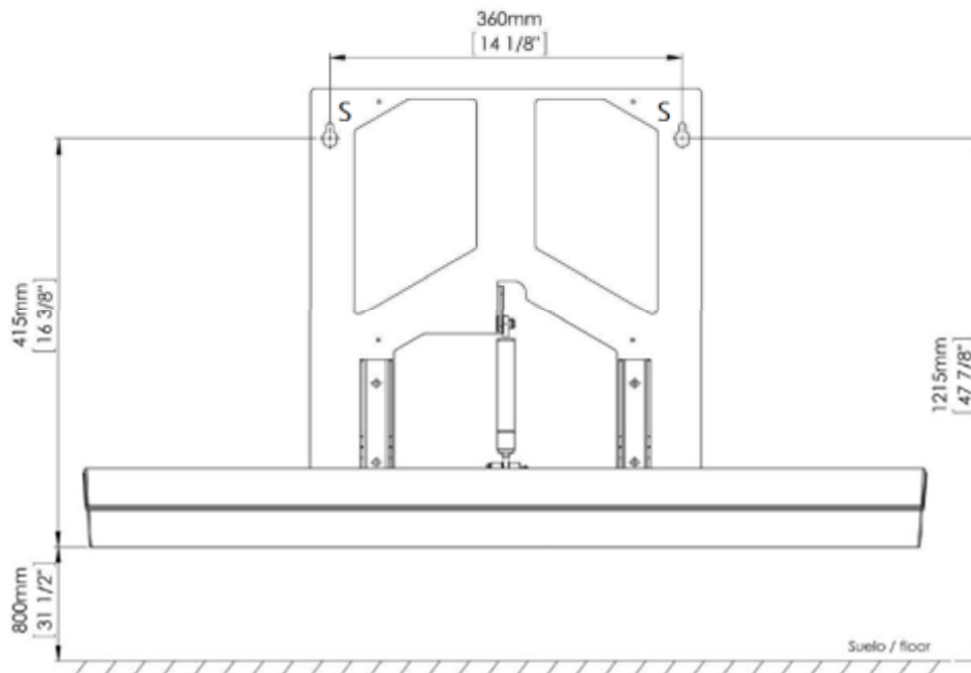

Warning: to ensure that the unit works properly and safely it must be installed according to the Mediclinics instructions supplied with the BabyMedi®.

The fixing systems supplied with this changing station are not suitable for installation on plasterboard or hollow walls. In order to install the unit on this type of wall, fastening anchors and tools specific for plasterboard or hollow walls must be used.

Due to the problems posed by installations on this type of walls, with regard to fixing, it is recommended that the installation is carried out by technicians specialized in installations on this type of walls. Mediclinics is not responsible for the installation of its changing stations on plasterboard or hollow walls.

INSTRUCTIONS FOR INSTALLING IONIZER BATTERIES

- Open the liner dispenser door.
- Install 3x AA/LR6 alkaline batteries paying attention to the correct polarity.
- Close the liner dispenser door.

Caution!!!

- Use only alkaline batteries AA/LR6 type.
- Do not mix batteries (old and new or different battery types).
- Exhausted batteries should be disposed properly.
- If the appliance is to be stored unused for a long period, remove the batteries.
- Do not short circuit the battery lid contacts.

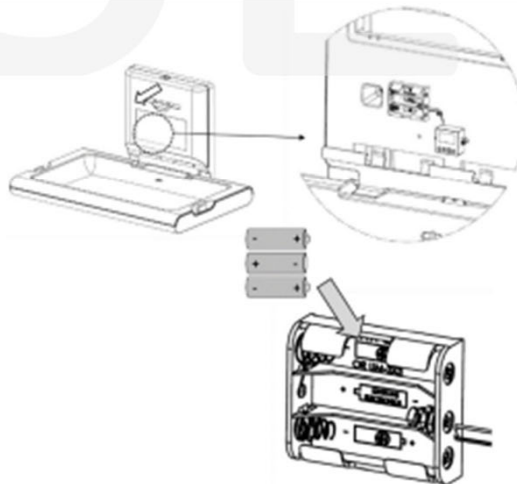

CERTIFICATIONS AND HOMOLOGATIONS



Ka Shing Enterprise (H.K.) Ltd.

ROOM 1706 NEW TERRITORIES TSUEN WAN HO LIK CENTRE, 66A SHA TSUI ROAD
Tel:26280661 Fax: 24902700
Email: project@kashingehk.com
Website: www.kashingehk.com

Ivan / Horace 26280661

E/ project@kashingehk.com

W/ <https://www.kashingehk.com/>

Prüfbericht-Nr.: 60329708-001 Test Report No.:		Seite 7 von 7 Page 7 of 7	
Absatz		Messergebnisse - Bemerkungen	Bewertung
Clause	Anforderungen - Prüfungen / Requirements - Tests	Measuring results - Remarks	Evaluation

5.3 Ergebnisse Babywickelstation - Mitte (mit Einschalten des Ionengenerators) /
results baby changing station – center (with switching on the ionen generator)

Testkeime / test germs	Anlieferungs- zustand / delivery status [KBE/100cm ²] / [CFU/100cm ²]	t ₀ [KBE/100cm ²] / [CFU/100cm ²]	t _{15min.} [KBE/100cm ²] / [CFU/100cm ²]	Reduktion nach 15 min. / reduction after 15 min.*	t _{2h} [KBE/100cm ²] / [CFU/100cm ²]	Reduktion nach 2 h / reduction after 2 h*
<i>A. niger</i> DSMZ 1957	88	> 400	6	> 98,5 %	0	> 99,9%
<i>P. pinophilum</i> DSMZ 1944	50	> 400	1,1 x 10 ²	> 72,5 %	1,1 x 10 ²	> 72,5 %
<i>C. albicans</i> DSMZ 1386	63	> 400	0	> 99,9%	0	> 99,9%
<i>S. aureus</i> DSMZ 799	31	> 400	0	> 99,9%	0	> 99,9%
<i>E. coli</i> DSMZ 1576	13	> 400	2,1 x 10 ²	> 47,5 %	6	> 98,5 %

* Berechnung der Reduktion = $\frac{\text{Anfangswert} - \text{Endwert}}{\text{Anfangswert}} \times 100 /$

calculation of reduction = $\frac{\text{initial value} - \text{end value}}{\text{initial value}} \times 100$

6 Bewertung / evaluation

Im Gesamten zeigen die Ergebnisse, dass das Material der Babywickelstation alleine keine keimreduzierenden Eigenschaften besitzt. Hier konnten nach 15 min. und 2 h Einwirkzeit des Inokulums volles Keimwachstum anhand der Abklatschproben auf dem Material detektiert werden. Beim Einschalten der integrierten, batteriebetriebenen Ozoneinrichtung wurde jedoch eine Keimreduktion erzielt. Diese beträgt bei *A. niger*, *C. albicans*, *S. aureus* und *E.coli* nach 2 h mindestens 98,5 %. Lediglich beim *P. pinophilum* war eine Reduktion von 72,5 % nach 2 h zu beobachten. /

Totally the results show that the material of the baby changing station itself doesn't possess any germ reducing properties. Here a complete germ growth could be detected on the material via contact samples after 15 min. and 2 h residence time. After switching on the integrated, battery operated ozone device a germ reduction was achieved. For A.niger, C.albicans, S.aureus and E.coli the reduction was at least 98,5 % after 2h. Only at P.pinophilum the reduction was 72,5 % after 2 h.

Rev.:01



Ka Shing Enterprise (H.K.) Ltd.

ROOM 1706 NEW TERRITORIES TSUEN WAN HO LIK CENTRE, 66A SHA TSUI ROAD
Tel:26280661 Fax: 24902700
Email: project@kashingehk.com
Website: www.kashingehk.com

Ivan / Horace 26280661

E/ project@kashingehk.com

W/ <https://www.kashingehk.com/>

Prüfbericht-Nr.: 60329708-001 Test Report No.:		Seite 6 von 7 Page 6 of 7	
Absatz		Messergebnisse - Bemerkungen	Bewertung
Clause	Anforderungen - Prüfungen / Requirements - Tests	Measuring results - Remarks	Evaluation

5 Ergebnisse / Results

5.1 Ergebnisse Kontrollmaterial (ohne Einschalten des Ionengenerators) / results control material (without switching on the ion generator)

Testkeime / test germs	Anlieferungs- zustand / delivery status [KBE/100cm ²] / [CFU/100cm ²]	t ₀ [KBE/100cm ²] / [CFU/100cm ²]	t _{15min.} [KBE/100cm ²] / [CFU/100cm ²]	Reduktion nach 15 min. / reduction after 15 min.*	t _{2h} [KBE/100cm ²] / [CFU/100cm ²]	Reduktion nach 2 h / reduction after 2 h*
<i>A. niger</i> DSMZ 1957	75	> 400	> 400	0	> 400	0
<i>P. pinophilum</i> DSMZ 1944	69	> 400	> 400	0	> 400	0
<i>C. albicans</i> DSMZ 1386	50	> 400	> 400	0	> 400	0
<i>S. aureus</i> DSMZ 799	63	> 400	> 400	0	> 400	0
<i>E. coli</i> DSMZ 1576	50	> 400	> 400	0	> 400	0

5.2 Ergebnisse Babywickelstation (ohne Einschalten des Ionengenerators) / results baby changing station (without switching on the ion generator)

Testkeime / test germs	Anlieferungs- zustand / delivery status [KBE/100cm ²] / [CFU/100cm ²]	t ₀ [KBE/100cm ²] / [CFU/100cm ²]	t _{15min.} [KBE/100cm ²] / [CFU/100cm ²]	Reduktion nach 15 min. / reduction after 15 min.*	t _{2h} [KBE/100cm ²] / [CFU/100cm ²]	Reduktion nach 2 h / reduction after 2 h*
<i>A. niger</i> DSMZ 1957	56	> 400	> 400	0	> 400	0
<i>P. pinophilum</i> DSMZ 1944	63	> 400	> 400	0	> 400	0
<i>C. albicans</i> DSMZ 1386	31	> 400	> 400	0	> 400	0
<i>S. aureus</i> DSMZ 799	38	> 400	> 400	0	> 400	0
<i>E. coli</i> DSMZ 1576	44	> 400	> 400	0	> 400	0

Rev.:01



Ka Shing Enterprise (H.K.) Ltd.

ROOM 1706 NEW TERRITORIES TSUEN WAN HO LIK CENTRE, 66A SHA TSUI ROAD
Tel:26280661 Fax: 24902700
Email: project@kashingehk.com
Website: www.kashingehk.com

Ivan / Horace 26280661

E/ project@kashingehk.com

W/ https://www.kashingehk.com/

List of types:

CP0016H-ASTM	Horizontal White finish (plastic)
CP0016H-I-ASTM CP0016H-ION-ASTM	Horizontal White finish (plastic) with Ion Generator
CP0016HCS-ASTM	Horizontal Satin finish (Stainless steel)
CP0016HCS-I-ASTM CP0016HCS-ION-ASTM	Horizontal Satin finish (Stainless steel) with Ion Generator
CP0016HCSB-ASTM	Horizontal Black finish (Stainless steel)
CP0016HCSB-I-AST CP0016HCSB-I-ASTM CP0016HCSB-ION-ASTM	Horizontal Black finish (Stainless steel) with Ion Generator
CP0016V-ASTM	Vertical White finish (plastic)
CP0016V-I-ASTM-I CP0016V-ION-ASTM	Vertical White finish (plastic) with Ion Generator
CP0016VCS-ASTM	Vertical Satin finish (Stainless steel)
CP0016VCS-I-ASTM CP0016VCS-ION-ASTM	Vertical Satin finish (Stainless steel) with Ion Generator
CP0016VCSB-ASTM	Vertical Black finish (Stainless steel)
CP0016VCSB-I-AST CP0016VCSB-I-ASTM CP0016VCSB-ION-ASTM	Vertical Black finish (Stainless steel) with Ion Generator

Certification Body
Date of issue:

Budapest, 2021-07-01



 Tamás László Tötös

TÜV Rheinland InterCert Kft. – Product Certification Body — H-1143 Budapest, Gizella út 51-57. — www.tuv.com

Ka Shing Enterprise (H.K.) Ltd.

 ROOM 1706 NEW TERRITORIES TSUEN WAN HO LIK CENTRE, 66A SHA TSUI ROAD
 Tel:26280661 Fax: 24902700
 Email: project@kashingehk.com
 Website: www.kashingehk.com

Ivan / Horace 26280661

 E/ project@kashingehk.com

 W/ <https://www.kashingehk.com/>

CERTIFICATE of Conformity



Certificate No.: MK 69265468 0001

Test Report No.: HU21RUDZ 001

Certificate Holder: Saniflow Corporation
3325 NW 70th Avenue Miami, FL 33122-1332.
USA

Product: Changing unit

Identification: Baby changing station

Product details:

Changing unit for children up to 3.5 years and less than 50 lb. The changing station must be fixed to the wall.

Used materials:

Polypropylene table, metal hinges, stainless steel cover (only by models „CS”), plastic textile strap.

For list of types see attachment

Tested according to: ASTM F2285-04
Standard Consumer Safety Performance Specification for Diaper Changing Tables for Commercial Use

This certificate refers to the above mentioned product. This is to certify that the test sample is in conformity with the requirements stated above. This certificate does not imply assessment of the series-production of the product and does not permit the use of a TÜV Rheinland mark of conformity.

Certification Body

Date of Issue:
Budapest, 2021-07-01

Tamás László Tötös

TÜV Rheinland InterCert Kft. – Product Certification Body — H-1143 Budapest, Gizella út 51-57. — www.tuv.com

Validity of certificate can be checked on www.CERTIPEDIA.com



Ka Shing Enterprise (H.K.) Ltd.

ROOM 1706 NEW TERRITORIES TSUEN WAN HO LIK CENTRE, 66A SHA TSUI ROAD
Tel:26280661 Fax: 24902700
Email: project@kashingehk.com
Website: www.kashingehk.com

Ivan / Horace 26280661
E/ project@kashingehk.com
W/ <https://www.kashingehk.com/>

Zertifikat

Certificate



Zertifikat Nr. *Certificate No.*
S 60154860

Blatt *Sheet*
0001

Ihr Zeichen *Client Reference* Unser Zeichen *Our Reference* Längstens gültig bis *Latest expiration date*
0010--60400671 002 23.02.2026 (day/mo/yr)

Genehmigungsinhaber *License Holder*
Mediclinics, SA
Industria, 54
08025 Barcelona
Spain

Fertigungsstätte *Manufacturing Plant*
Mediclinics S.A.
P.I. Can Oller - c/Catalunya, 9
08130 Sta. Perp. de Mogoda
Spain

Prüfzeichen *Test Mark*



www.tuv.com
ID 1111239356

Geprüft nach *Tested acc. to*
DIN EN 12221-1/12.13
EN 60335-2-65:2003+A1+A11

Zertifiziertes Produkt (Geräteidentifikation)
Certified Product (Product Identification)

Lizenzentgelte - Einheit
License Fee - Unit

Wickelkommode / Baby changing station

BABYMEDI CP0016H and CP0016V

The BABYMEDI CP0016H and CP0016V Baby Changing Station is installed in the public area as a wall-mounted folding changing unit.

Flap equipped with supporting gas spring;
two integrated hooks for hanging the diaper bag;
lockable liner dispenser;
Max. permissible total load: 11 kg;

Dimensions in mm:

CP0016H:

Width: 850, height: 570, depth: 104 - 570,
Changing area: 400 x 720, Type 1; weight: 12.3 kg

CP0016V:

Width: 890, height: 875, depth: 100 - 890,
Changing area: 405 x 715, Type 1; weight: 13.2 kg

The microbiological cleanability of the surfaces according to MS-0024552 is given.

Attachment with the product overview.

ANLAGE (Appendix): 1; Seite/page 1 - 1

Dem Zertifikat liegt unsere Prüf- und Zertifizierungsordnung zugrunde.
Produkt und Fertigungsstätte erfüllen § 20 und § 21 des
Produktsicherheitsgesetzes.

*This certificate is based on our Testing and Certification Regulation.
Product and production fulfill par § 20 and § 21 of the
Product Safety Law.*

TÜV Rheinland LGA Products GmbH, Tillystraße 2, 90431 Nürnberg

Tel. +49 221 806-1371 e-mail: cert-validity@de.tuv.com

Fax. +49 221 806-3935 <http://www.tuv.com/safety>

Ausstellungsdatum *Date of Issue* : 22.02.2021 (day/mo/yr)

Zertifizierungsstelle

K.-H. Heider



Ka Shing Enterprises (H.K.) Ltd.

ROOM 1706 NEW TERRITORIES TSUEN WAN HO LIK CENTRE, 66A SHA TSUI ROAD

Tel:26280661 Fax: 24902700

Email: project@kashingehk.com

Website: www.kashingehk.com

Ivan / Horace 26280661

E/ project@kashingehk.com

W/ <https://www.kashingehk.com/>

Anlage / Appendix 1

Zertifikat Nr. Certificate No.
S 60154860

Blatt Page
0001



Ihr Zeichen Client Reference

Unser Zeichen Our Reference
0010 -- 60400671 002

Ausstellungsdatum Date of issue
24.02.2021

Zertifizierte Produkte / Certified products:

Produktübersicht / Product overview:

Type CP0016H (Horizontal)

CP0016H - Plastic finish (12.3 kg)
CP0016H-ION or -I - Plastic finish with Ion Generator
CP0016HCS - Stainless steel finish (16.3 kg)
CP0016HCS-ION or -I - Stainless steel finish with Ion Generator

Type CP0016V (Vertical)

CP0016V - Plastic finish (13.2 kg)
CP0016V-ION or -I - Plastic finish with Ion Generator
CP0016VCS - Stainless steel finish (17.2 kg)
CP0016VCS-ION or -I - Stainless steel finish with Ion Generator

Zertifizierungsstelle

K.-H. Heider



Ka Shing Enterprise (H.K.) Ltd.

ROOM 1706 NEW TERRITORIES TSUEN WAN HO LIK CENTRE, 66A SHA TSUI ROAD
Tel: 26280661 Fax: 24902700
Email: project@kashingehk.com
Website: www.kashingehk.com

Ivan / Horace 26280661
E/ project@kashingehk.com
W/ <https://www.kashingehk.com/>

Zertifikat**Certificate**

Zertifikat Nr. *Certificate No.*
S 60154860

Blatt *Sheet*
0001

Ihr Zeichen <i>Client Reference</i>	Unser Zeichen <i>Our Reference</i>	Längstens gültig bis <i>Latest expiration date</i>
	0010--60400671 002	23.02.2026 (day/mo/yr)

Genehmigungsinhaber *License Holder*
Mediclinics, SA
Industria, 54
08025 Barcelona
Spain

Fertigungsstätte *Manufacturing Plant*
Mediclinics S.A.
P.I. Can Oller - c/Catalunya, 9
08130 Sta. Perp. de Mogoda
Spain

Prüfzeichen *Test Mark*

www.tuv.com
ID 1111236356

Geprüft nach *Tested acc. to*

DIN EN 12221-1/12.13
EN 60335-2-65:2003+A1+A11

**Zertifiziertes Produkt (Geräteidentifikation)
*Certified Product (Product Identification)***

**Lizenzentgelte - Einheit
*License Fee - Unit***

Wickelkommode / Babywickelstation

BABYMEDI CP0016H und CP0016V

Die BABYMEDI CP0016H und CP0016V Baby Changing Station wird im öffentlichen Bereich als wandhängende Klapp-Wickeleinrichtung montiert. Klappe mit unterstützender Gasfeder ausgestattet; zwei integrierte Haken für die Aufhängung der Wickeltasche; abschließbarer Liner Spender; Max. zulässige Gesamtlast: 11 kg;

Abmessungen in mm:

CP0016H:

Breite: 850, Höhe: 570, Tiefe: 104 - 570;

Wickelfläche: 400 x 720, Typ 1; Gewicht: 12,3 kg

CP0016V:

Breite: 890, Höhe: 875, Tiefe: 100 - 890;

Wickelfläche: 405 x 715, Typ 1; Gewicht: 13,2 kg

Die Mikrobiologische Reinigbarkeit der Oberflächen nach MS-0024552 ist gegeben. Anlage mit der Produktübersicht.

ANLAGE (Appendix): 1; Seite/page 1 - 1

Dem Zertifikat liegt unsere Prüf- und Zertifizierungsordnung zugrunde. Produkt und Fertigungsstätte erfüllen § 20 und § 21 des Produktsicherheitsgesetzes.
This certificate is based on our Testing and Certification Regulation. Product and production fulfill par § 20 and § 21 of the Product Safety Law.

TÜV Rheinland LGA Products GmbH, Tillystraße 2, 90431 Nürnberg

Tel.: +49 221 806-1371 e-mail: cert-validity@de.tuv.com

Fax: +49 221 806-3935 http://www.tuv.com/safety

Ausstellungsdatum *Date of Issue* : 22.02.2021 (day/mo/yr)

Zertifizierungsstelle

K.-H. Heider

**Ka Shing Enterprise (H.K.) Ltd.**

ROOM 1706 NEW TERRITORIES TSUEN WAN HO LIK CENTRE, 66A SHA TSUI ROAD

Tel:26280661 Fax: 24902700

Email: project@kashingehk.com

Website: www.kashingehk.com

Ivan / Horace 26280661

E/ project@kashingehk.com

W/ https://www.kashingehk.com/

MEDICLINICS, THE FIRST MANUFACTURER TO INTRODUCE THE MOST HYGIENIC METHOD OF SANITIZING A BABY CHANGING STATION: "ION HYGIENIC"



What is Ion Hygienic?

Ion Hygienic is a technology based on the negative ions generation that does what **no other baby changing station on the market can do**: it kills microorganisms such as virus and bacteria. Can you imagine a baby changing station installed in a mall, in an airport, in a restaurant, in a kindergarten or anywhere free of harmful microorganisms for your baby?

This is ION HYGENIC

How does Ion Hygienic work?

Ion Hygienic uses a **negative ion generator** that releases these particles into the air. These negative ions, together with the existing positive ions in the air, surround the surface membranes of harmful microorganisms and a chemical reaction takes place that physically breaks down these membranes of the bacteria and virus, killing them.

How can I be totally sure that Ion Hygienic kills harmful microorganisms for my baby, really?

Because Ion Hygienic **has been tested and approved by TÜV Rheinland** in its laboratories from Germany, as its **test report number 603229708-001** proves:

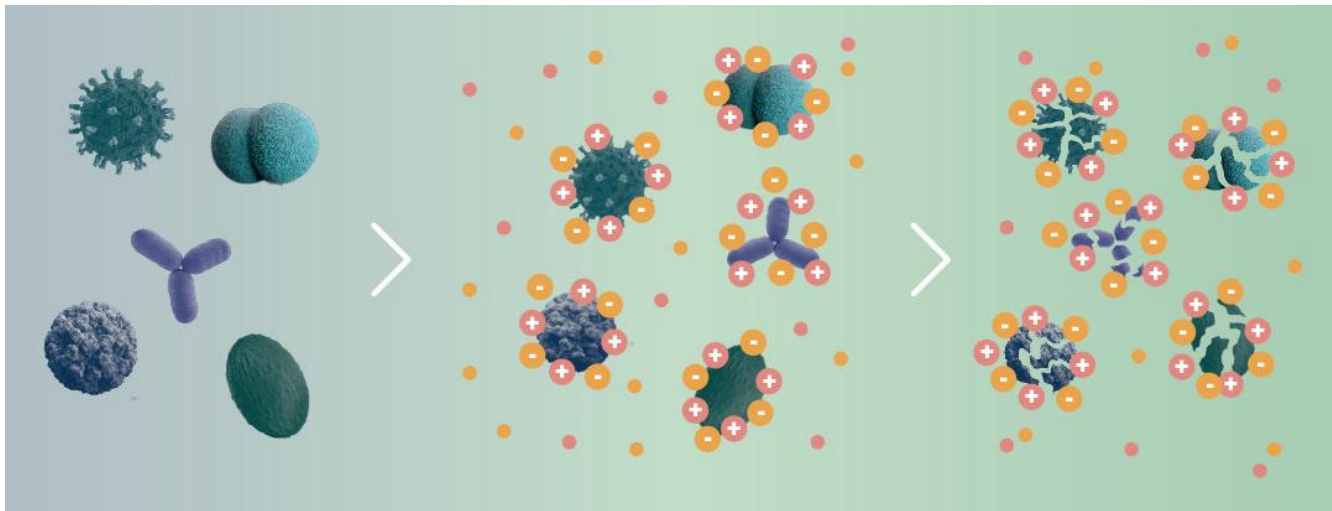
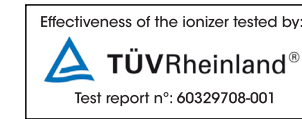

Test germs	Delivery status [CFU/100cm ²]	t ₀ [CFU/100cm ²]	t _{15min} [CFU/100cm ²]	Reduction after 15 min	t _{2h} [CFU/100cm ²]	Reduction after 2h
<i>A. niger</i> DSMZ 1957	88	>400	6	>98,5%	0	>99,9%
<i>P. pinophilum</i> DSMZ 1944	50	>400	1,1 x 10 ²	>72,5%	1,1 x 10 ²	>72,5%
<i>C. albicans</i> DSMZ 1386	63	>400	0	>99,9%	0	>99,9%
<i>S. aureus</i> DSMZ 799	31	>400	0	>99,9%	0	>99,9%
<i>E. coli</i> DSMZ 1576	13	>400	2,1 x 10 ²	>47,5%	6	>98,5%



Ion Hygienic technology is also available in our hand dryers **Dualflow Plus, Machflow, Speedflow** and **Speedflow Plus** included into the California Air Resources Board (CARB). See our listed hand dryers in the CARB's listings:

