

SANITARY WARE SPECIFICATION SHEET

Model: CP0016HCSB

Descriptions: Mediclinics (Spain) horizontal wall mounted polypropylene and matte black finish cover baby changing station. Loads of 50lbs with EN 12221-1 Registration No.HU21RUDZ 001

Dimensions: L860 x W100 (closed) / 570 (open) x H480 mm Material : Polyethylene and Stainless Steel
Manufacturer: Mediclinics, S.A. (Spain) Finish : Matte Black Epoxy Finish

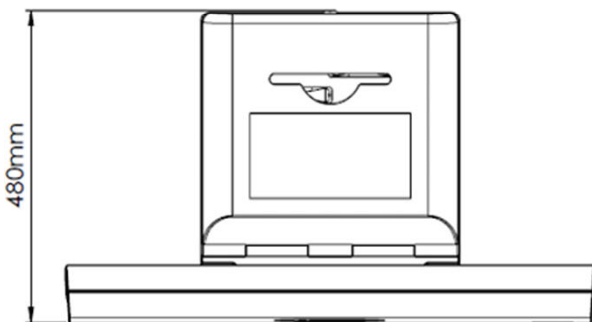
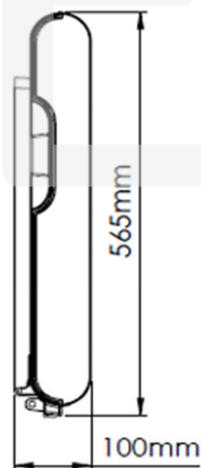
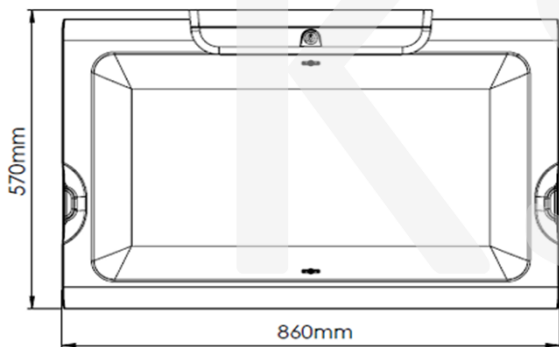

* All information of the above is for the reference only. No prior notice is made if any changes.



Ka Shing Enterprise (H.K.) Ltd.

ROOM 1706 NEW TERRITORIES TSUEN WAN HO LIK CENTRE, 66A SHA TSUI ROAD
Tel:26280661 Fax: 24902700
Email: project@kashingehk.com
Website: www.kashingehk.com

Ivan / Horace 26280661

E/ project@kashingehk.com

W/ <https://www.kashingehk.com/>



CP0016H
Polypropylene
White finish



CP0016HCSB
Polypropylene /Stainless steel
Matte black finish



CP0016HCS
Polypropylene /Stainless steel
Satin finish

PVD Coating

General Description

- Surface-mounted baby changing stations made of bacterial-resistant polypropylene and with stainless steel AISI 304 exterior (CP0016HCS and CP0016HCSB).
- BabyMedi® changing stations offer a very high level of safety and cleanliness being the ideal solution for public spaces such as, shopping centers, airports, public buildings, childcare centres, etc. Models suitable for high traffic facilities with high strength and durability.
- Their trendy and stylish design, allow these baby changing stations to blend into any space perfectly.
- Biocote® antimicrobial additive, based on ion silver technology, is embedded into its own surface, promoting an easy cleaning and reducing the growth of odor causing and staining microbes.
- BabyMedi® baby changing stations are supplied (inside the packing box) with child protection straps made of nylon.
- A pair of bag hooks (one at the right side and the other one at the left) help to keep personal belongings close and at hand.
- BabyMedi® units fully comply with the EN 12221-1 and EN 12221-2 standards that require baby changing stations be able to support a 50 Kg static load test during one hour. Moreover, units tested in our own laboratories have withstood loads over 100 kg.

Components and materials

- **CP0016H:** surface-mounted baby changing station made of polypropylene in white finish.
- **CP0016HCSB:** surface-mounted baby changing station made of polypropylene and with a stainless steel AISI 304 exterior, in matte black finish.
- **CP0016HCS:** surface-mounted baby changing station made of polypropylene and with a stainless steel AISI 304 exterior, in satin finish.
- **PVD coating:** consists of a very thin metallic layer available in gold, copper, bronze, or anthracite finish. Wear-resistant.
- **BED:** with a 1,900 cm² contoured changing surface area is made of polypropylene in white finish with Biocote® antimicrobial additive embedded into its own surface, promoting an easy cleaning and reducing the growth of odor causing and staining microbes.
- **LINER DISPENSER:** with lock is made of polypropylene and holds approximately 80 bed liners, minimizing operator refills and discouraging potential vandalism.
- **OPEN/CLOSE MECHANISM:** concealed from the user's view, it consists of a pair of reinforced hinges and a pneumatic cylinder, ensuring high durability and a smooth opening and closing of the baby changing station.
- **MOUNTING CHASSIS:** made of steel with a cataphoresis treatment. The corresponding mounting hardware is supplied, making very easy the installation of the unit to the wall.
- **FRONTAL CHASSIS:** (CP0016HCS and CP0016HCSB) made of one-piece AISI 304 stainless steel, 0.8 mm thick, fixed to the bottom of the bed by means of 4 bolts and 4 nuts, always concealed from the user's view, without joints or edges to ensure the user's safety, a better cleaning and an easy blending with other satin-finish accessories in the washroom.

Technical Specifications

Dimensions	L:860 x W:100 (closed)/ 570 (open) x H:480 mm
Weight (empty)	12.4 Kg (CP0016H) 16.0 Kg (CP0016HCS- HCSB)
Liner dispenser capacity	80 units
Recommended installation height	800 mm at lowest point
Recommended installation height (handicapped)	700 mm at lowest point

Dimensions

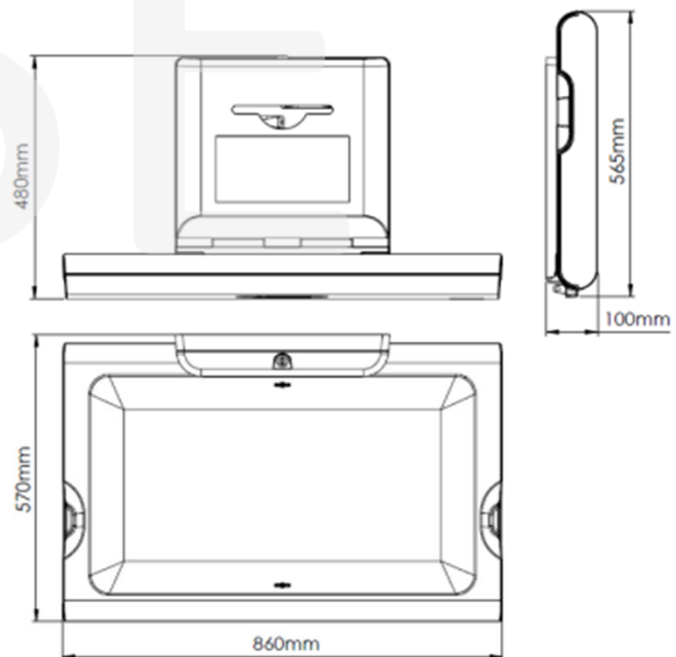

Dimensions ±4%



Ka Shing Enterprise (H.K.) Ltd.

ROOM 1706 NEW TERRITORIES TSUEN WAN HO LIK CENTRE, 66A SHA TSUI ROAD
Tel:26280661 Fax: 24902700
Email: project@kashingehk.com
Website: www.kashingehk.com

Ivan / Horace 26280661

E/ project@kashingehk.com

W/ <https://www.kashingehk.com/>

OPERATION

Open the BabyMedi® baby changing station. Place the baby in the centre of the bed and change your baby's diapers. Close the BabyMedi® station.

Under no circumstance should the baby be left unattended at any time on top of the baby changing station in order to avoid injury from falling or slipping.

Type 1 baby changing station with the purpose to be used from the children birth up to the age of 12 months and up to a weight of 11 Kg, in accordance with the manufacturer's instructions for use.

MOUNTING

Fix the mounting chassis on the wall using the provided screws through the mounting chassis holes (points indicated by an "S" in the figure below) and **always following, step by step, the detailed instructions contained in the "Installation and safety instructions manual"**, provided with the unit.

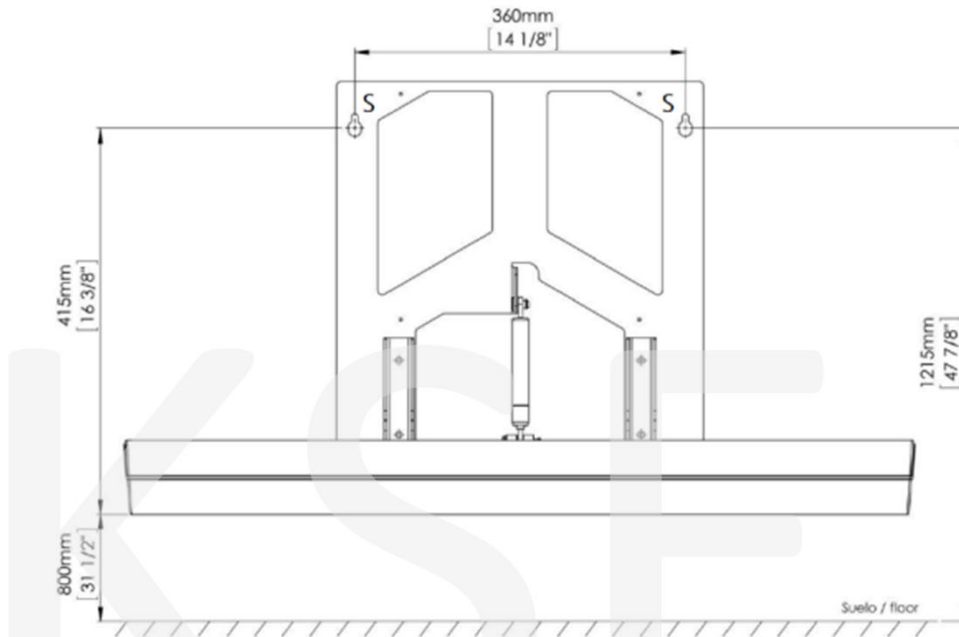

Warning: to ensure that the unit works properly and safely it must be installed according to the Mediclinics instructions supplied with the BabyMedi®.

The fixing systems supplied with this changing station are not suitable for installation on plasterboard or hollow walls. In order to install the unit on this type of wall, fastening anchors and tools specific for plasterboard or hollow walls must be used.

Due to the problems posed by installations on this type of walls, with regard to fixing, it is recommended that the installation is carried out by technicians specialized in installations on this type of walls. **Mediclinics is not responsible for the installation of its changing stations on plasterboard or hollow walls.**

CERTIFICATIONS AND HOMOLOGATIONS



Ka Shing Enterprise (H.K.) Ltd.

ROOM 1706 NEW TERRITORIES TSUEN WAN HO LIK CENTRE, 66A SHA TSUI ROAD
Tel:26280661 Fax: 24902700
Email: project@kashinghk.com
Website: www.kashinghk.com

Ivan / Horace 26280661

E/ project@kashinghk.com

W/ <https://www.kashinghk.com/>

Zertifikat**Certificate**
Zertifikat Nr. Certificate No.
 S 60154860

Blatt Sheet
 0001

Ihr Zeichen Client Reference	Unser Zeichen Our Reference	Längstens gültig bis Latest expiration date
	0010--60400671 002	23.02.2026 (day/mo/yr)

Genehmigungsinhaber License Holder
 Mediclinics, SA
 Industria, 54
 08025 Barcelona
 Spain

Fertigungsstätte Manufacturing Plant
 Mediclinics S.A.
 P.I. Can Oller - c/Catalunya, 9
 08130 Sta. Perp. de Mogoda
 Spain
Prüfzeichen Test Mark
 www.tuv.com
 ID 1111236356

Geprüft nach Tested acc. to
 DIN EN 12221-1/12.13
 EN 60335-2-65:2003+A1+A11

Zertifiziertes Produkt (Geräteidentifikation)
Certified Product (Product Identification)
Lizenzentgelte - Einheit
License Fee - Unit
Wickelkommode / Baby changing station

BABYMEDI CP0016H and CP0016V

The BABYMEDI CP0016H and CP0016V Baby Changing Station is installed in the public area as a wall-mounted folding changing unit.

 Flap equipped with supporting gas spring;
 two integrated hooks for hanging the diaper bag;
 lockable liner dispenser;
 Max. permissible total load: 11 kg;

Dimensions in mm:

CP0016H:

 Width: 850, height: 570, depth: 104 - 570,
 Changing area: 400 x 720, Type 1; weight: 12.3 kg

CP0016V:

 Width: 890, height: 875, depth: 100 - 890,
 Changing area: 405 x 715, Type 1; weight: 13.2 kg

The microbiological cleanability of the surfaces according to MS-0024552 is given.

Attachment with the product overview.

ANLAGE (Appendix): 1; Seite/page 1 - 1

 Dem Zertifikat liegt unsere Prüf- und Zertifizierungsordnung zugrunde.
 Produkt und Fertigungsstätte erfüllen § 20 und § 21 des Produktsicherheitsgesetzes.

 This certificate is based on our Testing and Certification Regulation.
 Product and production fulfill par § 20 and § 21 of the Product Safety Law.

TÜV Rheinland LGA Products GmbH, Tillystraße 2, 90431 Nürnberg

 Tel. +49 221 806-1371 e-mail: cert-validity@de.tuv.com
 Fax. +49 221 806-3935 http://www.tuv.com/safety

Übersetzung/Translation
Ausstellungsdatum Date of Issue : 22.02.2021 (day/mo/yr)
Zertifizierungsstelle
K.-H. Heider

Ka Shing Enterprise (H.K.) Ltd.

 ROOM 1706 NEW TERRITORIES TSUEN WAN HO LIK CENTRE, 66A SHA TSUI ROAD
 Tel:26280661 Fax: 24902700
 Email: project@kashingehk.com
 Website: www.kashingehk.com

Ivan / Horace 26280661

E/ project@kashingehk.com

W/ https://www.kashingehk.com/

Zertifikat

Certificate



Zertifikat Nr. *Certificate No.*
S 60154860

Blatt *Sheet*
0001

Ihr Zeichen <i>Client Reference</i>	Unser Zeichen <i>Our Reference</i>	Längstens gültig bis <i>Latest expiration date</i>
	0010--60400671 002	23.02.2026 (day/mo/yr)

Genehmigungsinhaber *License Holder*

Mediclinics, SA
Industria, 54
08025 Barcelona
Spain

Fertigungsstätte *Manufacturing Plant*

Mediclinics S.A.
P.I. Can Oller - c/Catalunya, 9
08130 Sta. Perp. de Mogoda
Spain

Prüfzeichen *Test Mark*



www.tuv.com
ID 1111236356

Geprüft nach *Tested acc. to*

DIN EN 12221-1/12.13
EN 60335-2-65:2003+A1+A11

Zertifiziertes Produkt (Geräteidentifikation)

Certified Product (Product Identification)

Lizenzentgelte - Einheit

License Fee - Unit

Wickelkommode / Babywickelstation

BABYMEDI CP0016H und CP0016V

Die BABYMEDI CP0016H und CP0016V Baby Changing Station wird im öffentlichen Bereich als wandhängende Klapp-Wickeleinrichtung montiert.

Klappe mit unterstützender Gasfeder ausgestattet; zwei integrierte Haken für die Aufhängung der Wickeltasche; abschließbarer Liner Spender;
Max. zulässige Gesamtlast: 11 kg;

Abmessungen in mm:

CP0016H:

Breite: 850, Höhe: 570, Tiefe: 104 - 570;

Wickelfläche: 400 x 720, Typ 1; Gewicht: 12,3 kg

CP0016V:

Breite: 890, Höhe: 875, Tiefe: 100 - 890;

Wickelfläche: 405 x 715, Typ 1; Gewicht: 13,2 kg

Die Mikrobiologische Reinigbarkeit der Oberflächen nach MS-0024552 ist gegeben. Anlage mit der Produktübersicht.

ANLAGE (Appendix): 1; Seite/page 1 - 1

Dem Zertifikat liegt unsere Prüf- und Zertifizierungsordnung zugrunde. Produkt und Fertigungsstätte erfüllen § 20 und § 21 des Produktsicherheitsgesetzes.

This certificate is based on our Testing and Certification Regulation. Product and production fulfill par § 20 and § 21 of the Product Safety Law.

TÜV Rheinland LGA Products GmbH, Tillystraße 2, 90431 Nürnberg

Tel.: +49 221 806-1371 e-mail: cert-validity@de.tuv.com

Fax: +49 221 806-3935 http://www.tuv.com/safety

Ausstellungsdatum *Date of Issue* : 22.02.2021 (day/mo/yr)

Zertifizierungsstelle

K.-H. Heider



Ka Shing Enterprise (H.K.) Ltd.

ROOM 1706 NEW TERRITORIES TSUEN WAN HO LIK CENTRE, 66A SHA TSUI ROAD

Tel:26280661 Fax: 24902700

Email: project@kashingehk.com

Website: www.kashingehk.com

Ivan / Horace 26280661

E/ project@kashingehk.com

W/ https://www.kashingehk.com/

Anlage / Appendix 1

Zertifikat Nr. Certificate No.
S 60154860

Blatt Page
0001



Ihr Zeichen Client Reference

Unser Zeichen Our Reference
0010 -- 60400671 002

Ausstellungsdatum Date of issue
24.02.2021

Zertifizierte Produkte / Certified products:

Produktübersicht / Product overview:

Type CP0016H (Horizontal)

CP0016H - Plastic finish (12.3 kg)
CP0016H-ION or -I - Plastic finish with Ion Generator
CP0016HCS - Stainless steel finish (16.3 kg)
CP0016HCS-ION or -I - Stainless steel finish with Ion Generator

Type CP0016V (Vertical)

CP0016V - Plastic finish (13.2 kg)
CP0016V-ION or -I - Plastic finish with Ion Generator
CP0016VCS - Stainless steel finish (17.2 kg)
CP0016VCS-ION or -I - Stainless steel finish with Ion Generator

Zertifizierungsstelle

K.-H. Heider



Ka Shing Enterprise (H.K.) Ltd.

ROOM 1706 NEW TERRITORIES TSUEN WAN HO LIK CENTRE, 66A SHA TSUI ROAD
Tel:26280661 Fax: 24902700
Email: project@kashingehk.com
Website: www.kashingehk.com

Ivan / Horace 26280661

E/ project@kashingehk.com

W/ <https://www.kashingehk.com/>

List of types:

CP0016H-ASTM	Horizontal White finish (plastic)
CP0016H-I-ASTM CP0016H-ION-ASTM	Horizontal White finish (plastic) with Ion Generator
CP0016HCS-ASTM	Horizontal Satin finish (Stainless steel)
CP0016HCS-I-ASTM CP0016HCS-ION-ASTM	Horizontal Satin finish (Stainless steel) with Ion Generator
CP0016HCSB-ASTM	Horizontal Black finish (Stainless steel)
CP0016HCSB-I-AST CP0016HCSB-I-ASTM CP0016HCSB-ION-ASTM	Horizontal Black finish (Stainless steel) with Ion Generator
CP0016V-ASTM	Vertical White finish (plastic)
CP0016V-I-ASTM-I CP0016V-ION-ASTM	Vertical White finish (plastic) with Ion Generator
CP0016VCS-ASTM	Vertical Satin finish (Stainless steel)
CP0016VCS-I-ASTM CP0016VCS-ION-ASTM	Vertical Satin finish (Stainless steel) with Ion Generator
CP0016VCSB-ASTM	Vertical Black finish (Stainless steel)
CP0016VCSB-I-AST CP0016VCSB-I-ASTM CP0016VCSB-ION-ASTM	Vertical Black finish (Stainless steel) with Ion Generator

Certification Body

Date of issue:

Budapest, 2021-07-01



.....
Tamás László Tötös

TÜV Rheinland InterCert Kft. – Product Certification Body — H-1143 Budapest, Gizella út 51-57. — www.tuv.com



Ka Shing Enterprise (H.K.) Ltd.

ROOM 1706 NEW TERRITORIES TSUEN WAN HO LIK CENTRE, 66A SHA TSUI ROAD
Tel:26280661 Fax: 24902700
Email: project@kashingehk.com
Website: www.kashingehk.com

Ivan / Horace 26280661

E/ project@kashingehk.com

W/ <https://www.kashingehk.com/>

CERTIFICATE of Conformity



Certificate No.: MK 69265468 0001

Test Report No.: HU21RUDZ 001

Certificate Holder: Saniflow Corporation
3325 NW 70th Avenue Miami, FL 33122-1332.
USA

Product: Changing unit

Identification: Baby changing station

Product details:

Changing unit for children up to 3.5 years and less than 50 lb. The changing station must be fixed to the wall.

Used materials:

Polypropylene table, metal hinges, stainless steel cover (only by models „CS”), plastic textile strap.

For list of types see attachment

Tested according to: ASTM F2285-04
Standard Consumer Safety Performance Specification for Diaper Changing Tables for Commercial Use

This certificate refers to the above mentioned product. This is to certify that the test sample is in conformity with the requirements stated above. This certificate does not imply assessment of the series-production of the product and does not permit the use of a TÜV Rheinland mark of conformity.

Certification Body

Date of issue:
Budapest, 2021-07-01

A handwritten signature in blue ink, appearing to read "Tötös Tamás".
Tamás László Tötös

TÜV Rheinland InterCert Kft. – Product Certification Body — H-1143 Budapest, Gizella út 51-57. — www.tuv.com

Validity of certificate can be checked on www.CERTIPEDIA.com



Ka Shing Enterprise (H.K.) Ltd.

ROOM 1706 NEW TERRITORIES TSUEN WAN HO LIK CENTRE, 66A SHA TSUI ROAD
Tel:26280661 Fax: 24902700
Email: project@kashingehk.com
Website: www.kashingehk.com

Ivan / Horace 26280661
E/ project@kashingehk.com
W/ <https://www.kashingehk.com/>