









PROJECT		REF		REV	ITEM CODE	
LOCATION		DATE			PAGE	

SANITARY WARE SPECIFICATION SHEET

<p>Item Descriptions</p> <p>Delabie (France) "BINOPTIC" Deck-mounted electronic liquid soap dispenser with 230/6V transformer 1-litre</p> <p>Model 512021P</p> <p>Spout length 105mm</p> <p>Material Chrome Plated</p> <p>Manufacturer Delabie (France)</p> <p>Source Ka Shing Enterprises (H.K.) Limited Mr. Ivan Lau / Mr. Gilman Yuen</p> <p>Contact Tel/Fax (852) 2628-0661 / (852) 2490-2700</p> <p>E-mail project@kashingehk.com</p> <p>Website www.kashingehk.com</p>	<p>Illustration/ Drawing</p>  <ul style="list-style-type: none">  Total hygiene: no manual contact  Comfort: automatic soap dispenser  No waste pump dispenser  Liquid or foam soap or gel dispenser 														
<p>DESCRIPTION</p> <p>BINOPTIC deck-mounted electronic soap dispenser Ref. 512021P (Chrome Plated) Ref. 512021S (Satin finish 304 stainless steel) Ref. 512021BK (Matte black 304 stainless steel) Deck-mounted electronic soap dispenser. Liquid soap, foam soap or hydroalcoholic gel dispenser. No manual contact: hands are automatically detected by infrared cell. Spout made from chrome-plated 304 stainless steel. No waste pump dispenser. Separate electronic unit and removable tank for installation under the basin. Automatic soap dispenser: mains supply with 230/6V transformer. For vegetable-based liquid soap with a maximum viscosity of 3,000 mPa.s or specialist foam soap. Compatible with hydroalcoholic gel. Spout length: 105mm. Supplied with a 1 litre tank.</p> 	<p>TECHNICAL CHARACTERISTICS</p> <p>BINOPTIC deck-mounted electronic soap dispenser - Ref. 512021P</p> <table border="1"> <tr> <td>Supply</td> <td>Mains supply 230/6 V</td> </tr> <tr> <td>Technology</td> <td>Infrared sensor</td> </tr> <tr> <td>Drop height</td> <td>58mm</td> </tr> <tr> <td>Spout length</td> <td>105mm</td> </tr> <tr> <td>Volume</td> <td>1 litre tank</td> </tr> <tr> <td>Finish</td> <td>Chrome-plated 304 stainless steel</td> </tr> <tr> <td>Norms</td> <td>CE</td> </tr> </table> 	Supply	Mains supply 230/6 V	Technology	Infrared sensor	Drop height	58mm	Spout length	105mm	Volume	1 litre tank	Finish	Chrome-plated 304 stainless steel	Norms	CE
Supply	Mains supply 230/6 V														
Technology	Infrared sensor														
Drop height	58mm														
Spout length	105mm														
Volume	1 litre tank														
Finish	Chrome-plated 304 stainless steel														
Norms	CE														

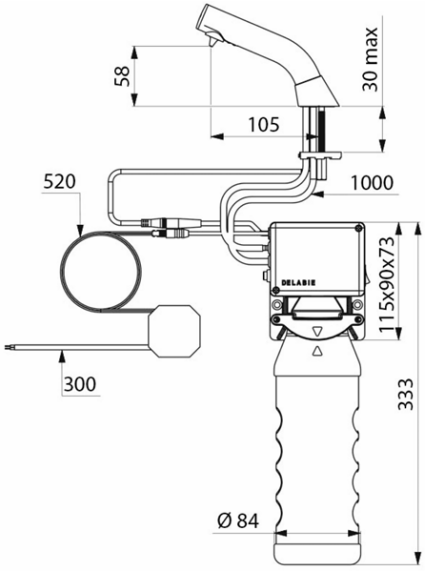
Note:

* All information of the above is for the reference only. No prior notice is made if any changes.

