

Soap dispenser

SANITARY WARE SPECIFICATION SHEET

Model: DJF0038ACS

Descriptions: Mediclinics (Spain) stainless steel AISI 304 wall-mounted automatic foam soap dispenser in satin finish AC supply 1 L capacity

Dimensions: L110 x W120 x H240 mm

Material : Stainless Steel

Manufacturer: Mediclinics, S.A. (Spain)

Finish : Satin Finish

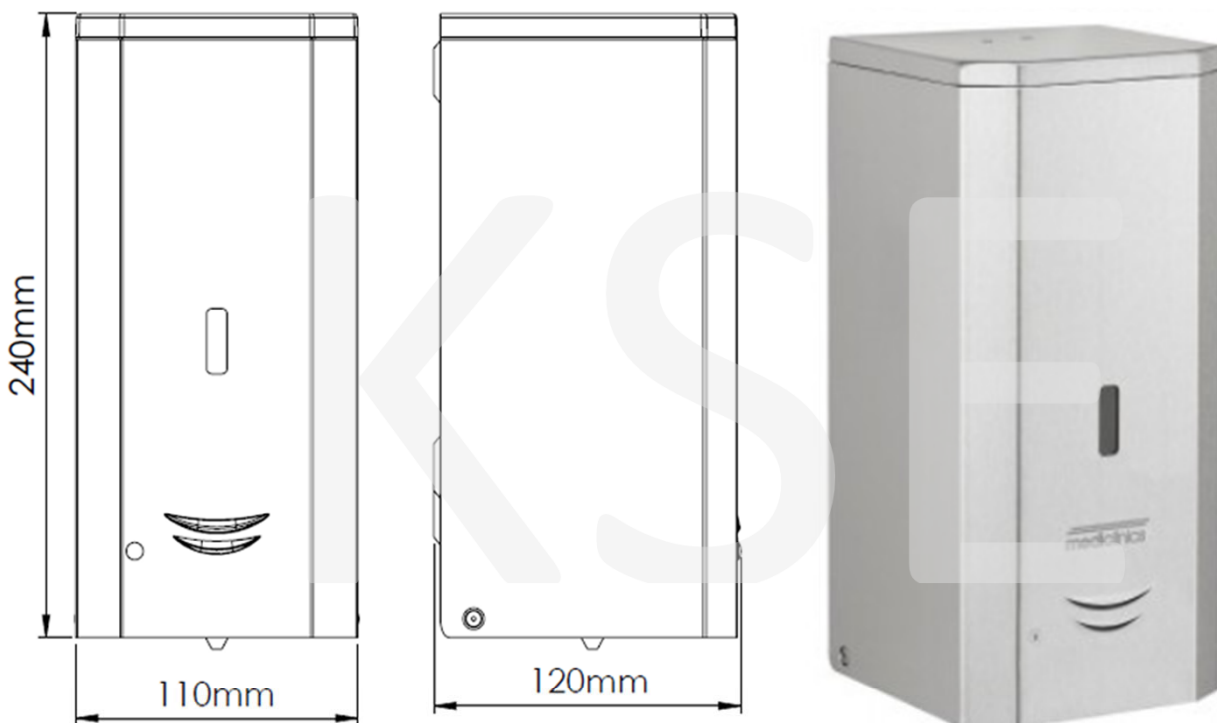

* All information of the above is for the reference only. No prior notice is made if any changes.



Ka Shing Enterprise (H.K.) Ltd.

ROOM 1706 NEW TERRITORIES TSUEN WAN HO LIK CENTRE, 66A SHA TSUI ROAD
Tel:26280661 Fax: 24902700
Email: project@kashingehk.com
Website: www.kashingehk.com

Ivan / Gilman 26280661

E/ project@kashingehk.com

W/ <https://www.kashingehk.com/>



DJF0038A
White epoxy finish



DJF0038AB
Matte black epoxy finish



DJF0038AC
Bright finish



DJF0038ACS
Satin finish

Technical specifications

General Description

- Automatic wall-mounted foam soap dispenser made of stainless steel AISI 304, 0.8 mm thick and with a total capacity of 1 L. Manufactured in four different finishes (white, black, bright and satin)
 - They have a functional, robust and trendy design that matches the new range of Mediclinics bathroom accessories. This allows this soap dispenser to blend into any space perfectly.
 - Soap dispensers suitable for high traffic facilities and for public use.
 - Operates on 6 AA alkaline batteries (not provided) or optionally, with an AC adapter. Order reference DJF0038A/B/C/CS-TRAFO to receive the automatic soap dispenser able to be connected to the mains with the AC adapter.
 - It is recommended to use foam soaps with the following characteristics: - Maximum alcohol content of 80% - Density between 0.95 and 1.05 kg / dm³ - Use specific foam products
 - It does not support foam soaps that contain methanol, chlorine or solid or abrasive particles.
 - Screws and plastic plugs to mount on a brick wall supplied.
- Components & materials
- DJF0038A: Stainless steel AISI 304, white epoxy finish.
 - DJF0038AB: Stainless steel AISI 304, black matte epoxy finish.
 - DJF0038AC: Stainless steel AISI 304, bright finish.
 - DJF0038ACS: Stainless steel AISI 304, satin finish.
 - COVER: made of stainless steel AISI 304, 0.8 mm thick.
 - WALL PLATE: made of stainless steel AISI 304, 0.8 mm thick. It is mounted on the wall by means of four Ø4 stainless steel screws (provided) with their corresponding Ø 6mm plastic plugs (also provided).
 - INNER PLASTIC TANK: prevents oxidation and that can be easily removed for cleaning and disinfection purposes.
 - INFRA-RED DETECTION: with a 5 cm hands detection range.
 - VALVE: Anti-drip corrosion resistant valve that dispenses 1.0 ml of soap per service. This anti-drip valve, which dispenses foam soap, is easily interchangeable with the valves of the other soap dispensers of the same line.
 - HINGED COVER: for operator convenience and speed of service. Opening on top with provided Mediclinics key that allows soap refill.
 - POWER: 6 AA alkaline batteries (not provided) or optionally, AC adapter. Order reference DJF0038A/B/C/CS-TRAFO to receive the automatic soap dispenser able to be connected to the mains with the electrical transformer.

Dimensions	<i>240 x 110 x 120 mm</i>
Maximum capacity	<i>1 L</i>
Body, cover & base plate thickness	<i>0.8 mm</i>
Inner Tank Thickness	<i>2.5 mm</i>
Net weight	<i>1.25 Kg</i>
Quantity dispensed per pump	<i>1.0 ml</i>

Dimensions

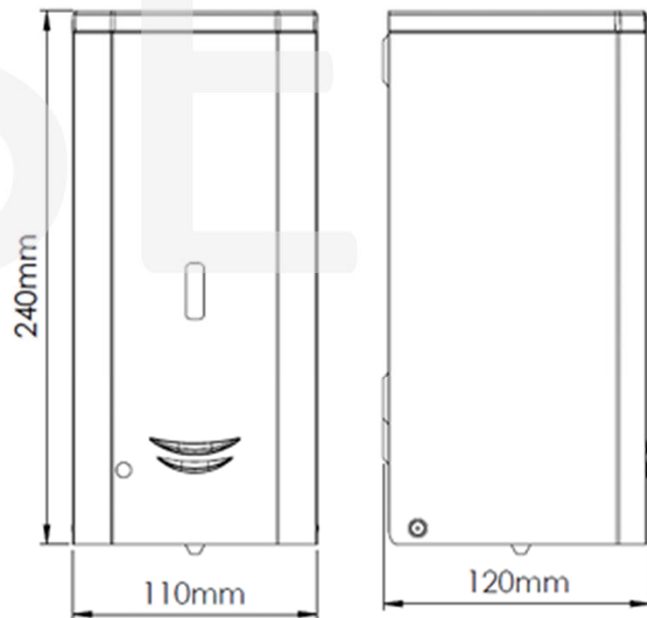

Dimensions: ± 4%



Ka Shing Enterprise (H.K.) Ltd.

ROOM 1706 NEW TERRITORIES TSUEN WAN HO LIK CENTRE, 66A SHA TSUI ROAD
 Tel:26280661 Fax: 24902700
 Email: project@kashingehk.com
 Website: www.kashingehk.com

Ivan / Gilman 26280661

E/ project@kashingehk.com

W/ <https://www.kashingehk.com/>

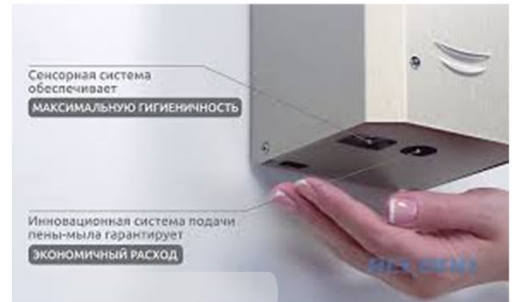

MOUNTING TEMPLATE

Fix the soap dispenser through the holes of the wall and floor plates, using the stainless steel screws supplied and taking into account the distances of the points indicated by an "S" in the next figure:

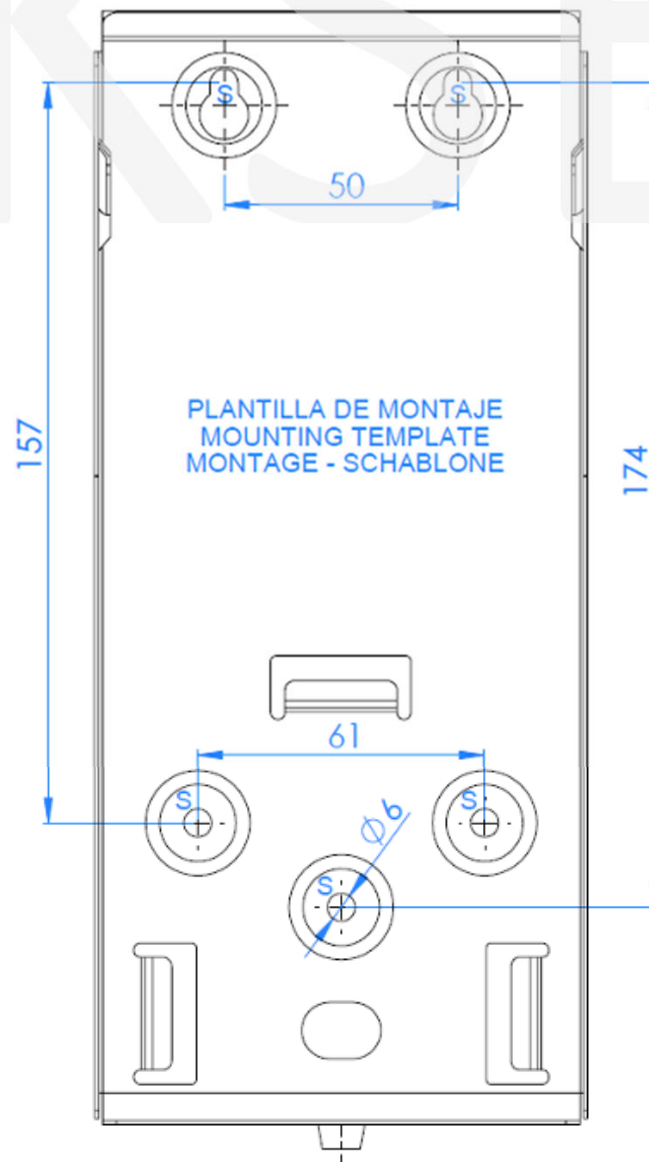

VERY IMPORTANT: do not install this soap dispenser inside the shower, as its electrical components can be seriously damaged by water and the dispenser stops working. If you choose the configuration with an electric converter, install it away from any source of water.



Ka Shing Enterprise (H.K.) Ltd.

ROOM 1706 NEW TERRITORIES TSUEN WAN HO LIK CENTRE, 66A SHA TSUI ROAD
Tel: 26280661 Fax: 24902700
Email: project@kashingehk.com
Website: www.kashingehk.com

Ivan / Gilman 26280661

E/ project@kashingehk.com

W/ <https://www.kashingehk.com/>

Dosificador Automático de Jabón

Automatic Soap Dispenser

Instrucciones / Instructions

Componentes del dosificador

Soap Dispenser components

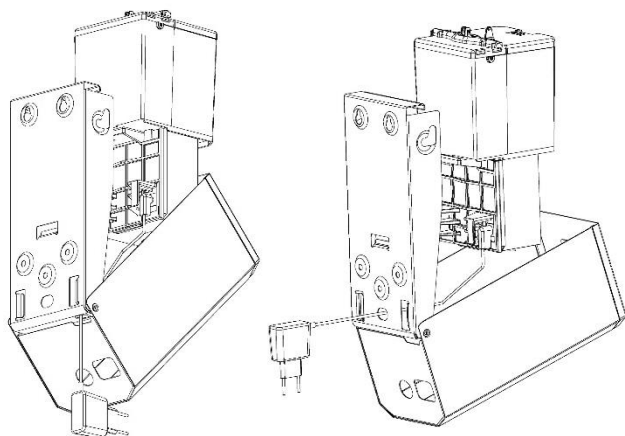
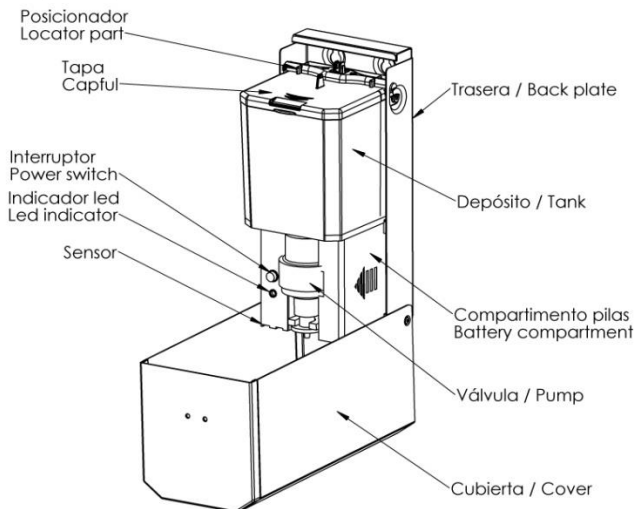

El transformador (opcional) se puede montar por la parte inferior o trasera del product
 The power adaptor (optional) could be assembled by the lower or back part of the product

Instalación / Installation

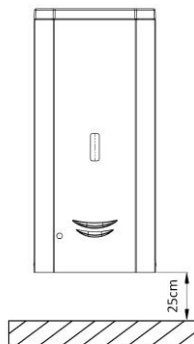

Instale el dosificador en una superficie limpia y lisa
 Se deben dejar por lo menos 25cm de espacio libre debajo de la unidad
 Look for a clean and smooth surface to install the Soap Dispenser
 Keep at least 25cm of free space below the unit

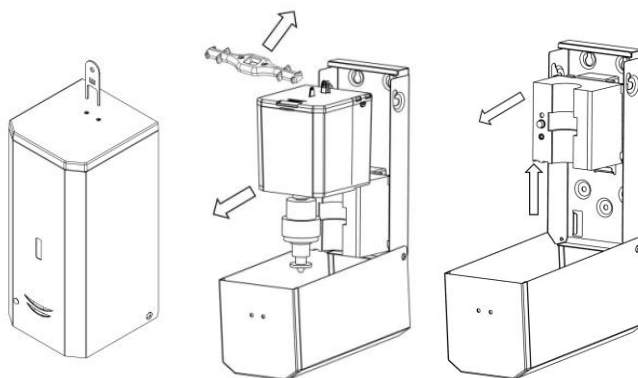

Abra la unidad con la llave provista
 Extraiga el posicionador del depósito y el depósito con válvula
 Extraiga el mecanismo
 Open the unit with the provided key
 Remove the soap tank locator and the soap tank with the valve
 Remove the mechanism

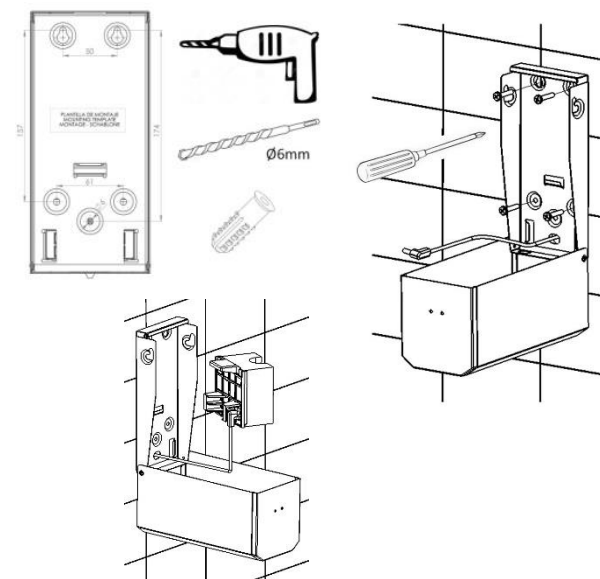

Taladrar la pared usando la plantilla de montaje provista
 Pase el cable por uno de los dos agujeros provistos a tal efecto, en caso de usar transformador
 Atornille firmemente la unidad a la pared (tornillería incluida)
 Drill the wall using the provided mounting template
 Route the cable through one of the provided holes if you are using the power adaptor
 Firmly screw the unit to the wall (screw bag included)

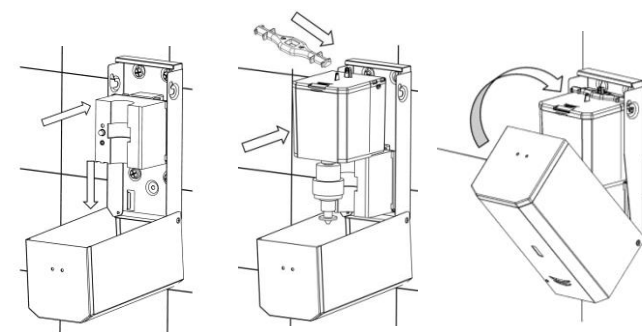

Ensamble de nuevo el mecanismo , el depósito con válvula y el posicionador del depósito
 Cierre la unidad
 Reassembly the mechanism, the soap tank with the valve and the soap tank locator
 Close the unit

Instrucciones de funcionamiento

Operating instructions

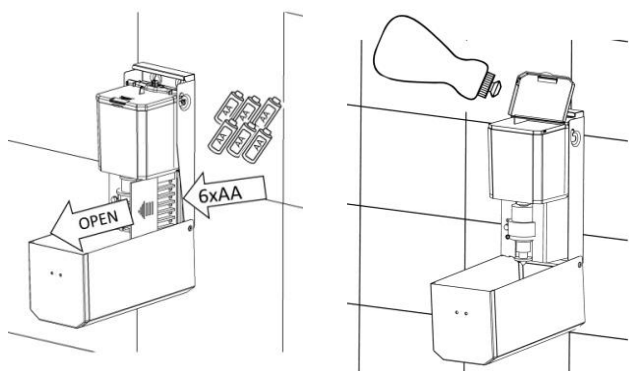

Abra la unidad con la llave provista
 Quite la tapa de las baterías e instale 6 pilas alcalinas 1.5V AA. El LED parpadeará 3 veces
 En caso de usar transformador no es necesario instalar las baterías
*Open the unit with the provided key
 Remove the battery cover and install 6 Alkaline 1.5V AA batteries. The LED will blink 3 times
 If you are using the power adapter it is not necessary to install the batteries*



Abra la tapa del depósito y rellene con jabón. Cierre la unidad
Open the soap tank cover and fill with soap. Close the unit

Poner la mano bajo la unidad. El LED azul parpadeará y el jabón será dispensado
Place the hand below the unit. The blue LED blinks and the soap is dispensed

Es posible que en un primer uso la válvula requiera ser purgada. Accionar la válvula de forma manual hasta que salga jabón/espuma/spray correctamente
On the first use, the valve could need to be primed. Actuate the valve manually till it correctly dispenses soap/foam/spray

Si el LED rojo parpadea reemplace las baterías
If the red LED blinks the batteries must be replaced

Recambios / Spare parts

Depósito, válvula y mecanismo GEL
 GEL tank, valve and mechanism
 RC9372001SMD

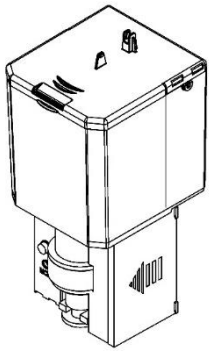

Depósito, válvula y mecanismo ESPUMA
 FOAM tank, valve and mechanism
 RC9372002SMD

Depósito, válvula y mecanismo SPRAY
 SPRAY tank, valve and mechanism
 RC9372010SMD

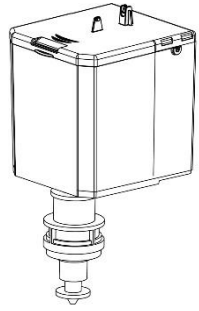

Depósito y válvula GEL
 GEL tank and valve
 RC9372037SMD

Depósito y válvula ESPUMA
 FOAM tank and valve
 RC9372038SMD

Depósito y válvula SPRAY
 SPRAY tank and valve
 RC9372039SMD

Mecanismo GEL
 GEL mechanism
 RC9372003SMD

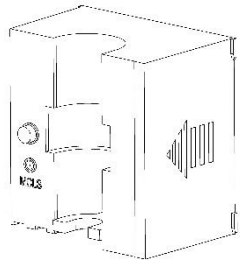

Mecanismo ESPUMA
 FOAM mechanism
 RC9372004SMD

Mecanismo SPRAY
 SPRAY mechanism
 RC9372012SMD

Actuador GEL
 GEL actuator
 RC9372005SMD

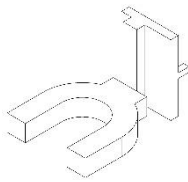

Actuador ESPUMA
 FOAM actuator
 RC9372006SMD

Actuador SPRAY
 SPRAY actuator
 RC9372011SMD

Adaptador de corriente
 Power adapter
 Enchufe tipo C / Plug type C
 (UE, South America, Asia, etc.) - KA0090



Adaptador de corriente
 Power adapter
 Enchufe tipo A / Plug type A
 (USA, Canada, etc.) - KA0090-A



Adaptador de corriente
 Power adapter
 Enchufe tipo G / Plug type G
 (UK, Ireland, Malta, etc.) - KA0090-G



Posicionador
 Locator
 RC9481032SMD

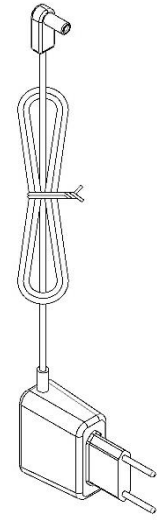
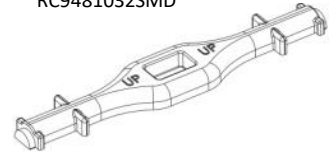

Especificaciones / Specifications

Material del cuerpo (todas las versiones) <i>Body material (all versions)</i>	Acero inoxidable / <i>Stainless Steel</i> AISI 304
Dimensiones <i>Dimensions</i>	240 x 120 x 120 mm
Capacidad del depósito <i>Soap Tank Capacity</i>	1000 ml
Batería <i>Battery</i>	6 x Alkaline AA (1.5V) or 9V power adapter
Temperatura funcionamiento <i>Room Temperature</i>	+5°C - +40°C
Cantidad de jabón dispensada <i>Dispensed soap quantity</i>	1-2 ml (liquido/liquid - gel) 0.6-0.8 ml (espuma/foam) 0.15-0.20 ml (spray)
Viscosidad recomendada (liquido-gel) <i>Suggested viscosity (liquid-gel)</i>	500-2500 cps
Porcentaje máximo de alcohol en jabón <i>Max. Alcohol content in soap</i>	80%
MEDICLINICS, S.A. Industria, 54 E-08025 BARCELONA SPAIN	

96310375SMD - V.14 - JUN2020