

## SANITARY WARE SPECIFICATION SHEET

Model: 5834

Descriptions: Delabie (France) Twin hole wall mount pre-rinse kitchen sink mixer set with swivelling tubular spout

Dimensions: Refer to drawing

Material : Chrome plated

Manufacturer: Delabie (France)

Finish : Silver

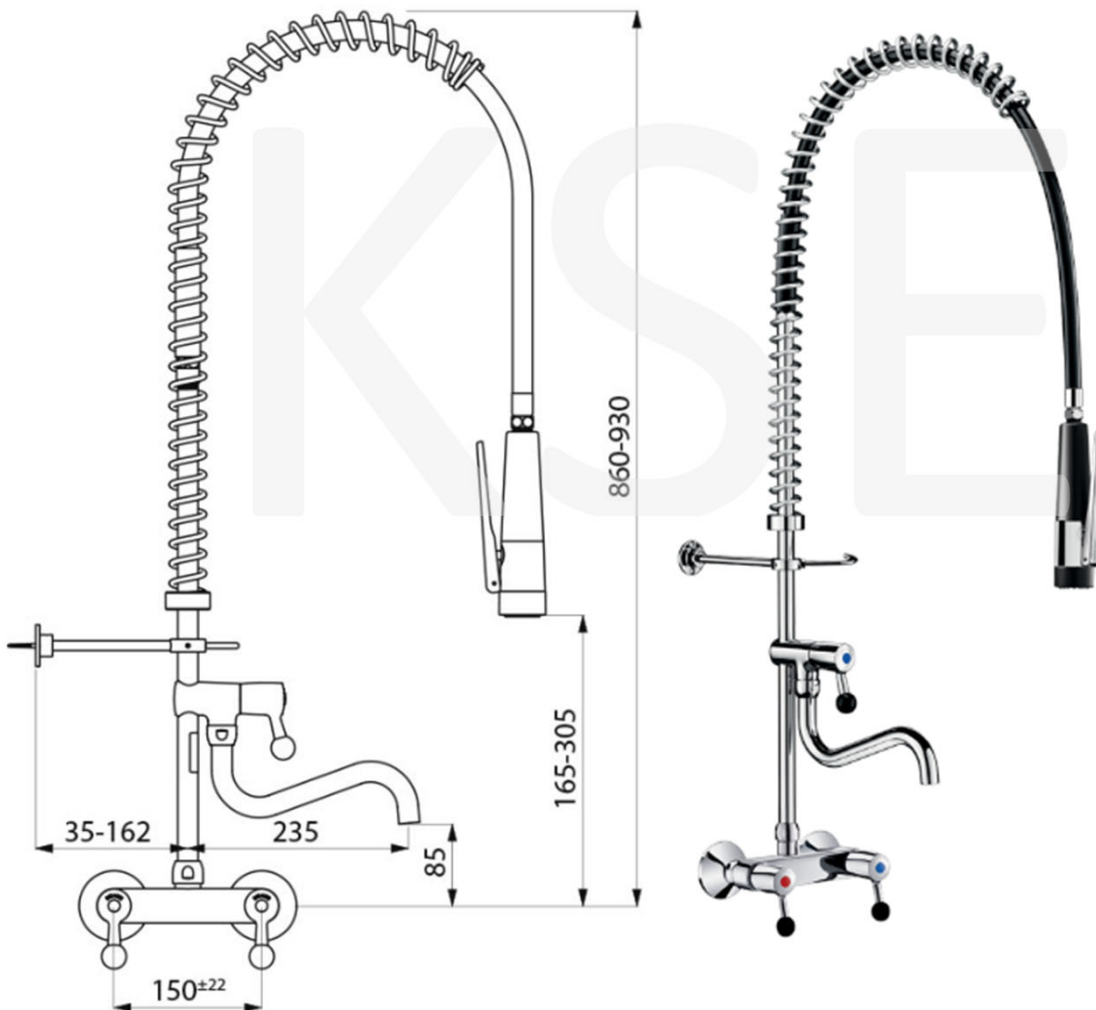

\* All information of the above is for the reference only. No prior notice is made if any changes.



**Ka Shing Enterprise (H.K.) Ltd.**

ROOM 1706 NEW TERRITORIES TSUEN WAN HO LIK CENTRE, 66A SHA TSUI ROAD  
Tel:26280661 Fax: 24902700  
Email: project@kashingehk.com  
Website: www.kashingehk.com

Ivan / Gilman 26280661

E/ project@kashingehk.com

W/ <https://www.kashingehk.com/>

## TECHNICAL CHARACTERISTICS

Wall-mounted pre-rinse mixer set with swivelling tubular spout  
Ref. 5834

Connector	M1/2"
Height	860 - 930mm
Drop height	165 - 305mm
Flow rate	Bib tap 25 lpm; 10 lpm via the hand spray
Width to the wall	35 - 162mm
Finish	Chr

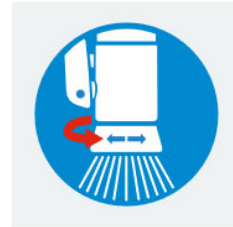

Hand spray - rain effect



Long Life valve head with an ergonomic ball lever

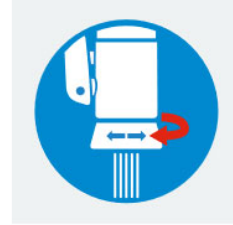

Hand spray - concentrated jet



Full flow rate within the first 90°

### DESCRIPTION

**Wall-mounted pre-rinse mixer set with swivelling tubular spout  
Ref. 5834**

#### Specification description

Complete pre-rinse set with bib tap suitable for intensive use in professional kitchens.

F3/4" wall-mounted mixer with adjustable centres with:

- valve heads with reinforced mechanisms and ergonomic controls.
- offset inlet connections, M1/2" M3/4".
- non-return valves integrated in the mixer.

Bib tap with swivelling tubular spout L. 200mm.

- 25 lpm full flow rate achieved within the first 1/4-turn.
- valve head with reinforced mechanism and ergonomic control.

Black handset with adjustable jet and 10 lpm flow rate at the outlet (ref. 433009).

Scale-resistant handset with shock-resistant tip.

Black, reinforced food-grade flexible hose L. 0.95m.

3/4" brass column.

Adjustable wall bracket.

Stainless steel spring guide.

#### High performance flexible hose

The flexible hose on the pre-rinse assembly is made from PVC reinforced with a braided interior.

It will withstand pressure up to 40 bar and temperatures up to 70°C.

It has a stain-resistant coating, stainless steel hose crimps and a PVC sheath on the stress area, and an anti-torsion rotating nut.

Subject to intensive use in professional kitchens, the catering industry and for fish preparation, etc..., pre-rinse sprays must be robust and reliable. Specifically designed to withstand high stress loads, DELABIE's pre-rinse sprays are also functional, easy to handle, and ensure effective filling and cleaning.

### ADVANTAGES



Rapid fill: full flow rate within 1/4 turn



Anti-torsion rotating nut and PVC sheath



Comfort: ergonomic controls, swivelling spout



Hygiene: PVC flexible, scale-resistant handset



**Ka Shing Enterprise (H.K.) Ltd.**

ROOM 1706 NEW TERRITORIES TSUEN WAN HO LIK CENTRE, 66A SHA TSUI ROAD  
Tel:26280661 Fax: 24902700  
Email: project@kashingehk.com  
Website: www.kashingehk.com

Ivan / Gilman 26280661

E/ project@kashingehk.com

W/ <https://www.kashingehk.com/>

# DELABIE

64../65../66../56..

**NT GC**  
Indice H

**FR** Ensemble de prélavage avec douchette avec ou sans robinet de puisage

**EN** Pre-rinse sets with trigger-operated hand spray with or without bib tap

**DE** Geschirrspülarmatur mit Handbrause mit oder ohne Auslaufventil

**PL** Zestaw do mycia wstępnego z pistoletem, z zaworem czerpalnym lub bez

**NL** Voorspoelkolom met sproeier en met of zonder tapkraan



**FR** Purger soigneusement les canalisations avant la pose et la mise en service du produit.

**EN** Thoroughly flush the pipes to remove any impurities before installing and commissioning the product.

**DE** Vor Montage und Inbetriebnahme des Produkts die Anschlussleitungen regelkonform spülen.

**PL** Dokładnie wypłukać instalację przed montażem i uruchomieniem produktu.

**NL** Spoel zorgvuldig de leidingen alvorens tot installatie of ingebruikname van de kraan over te gaan.

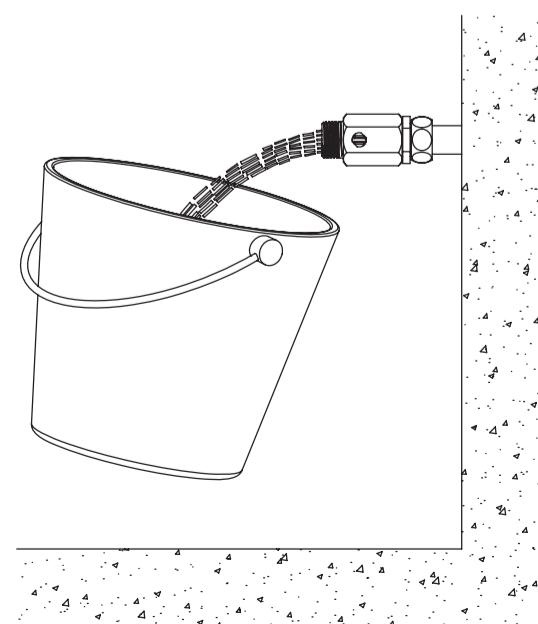

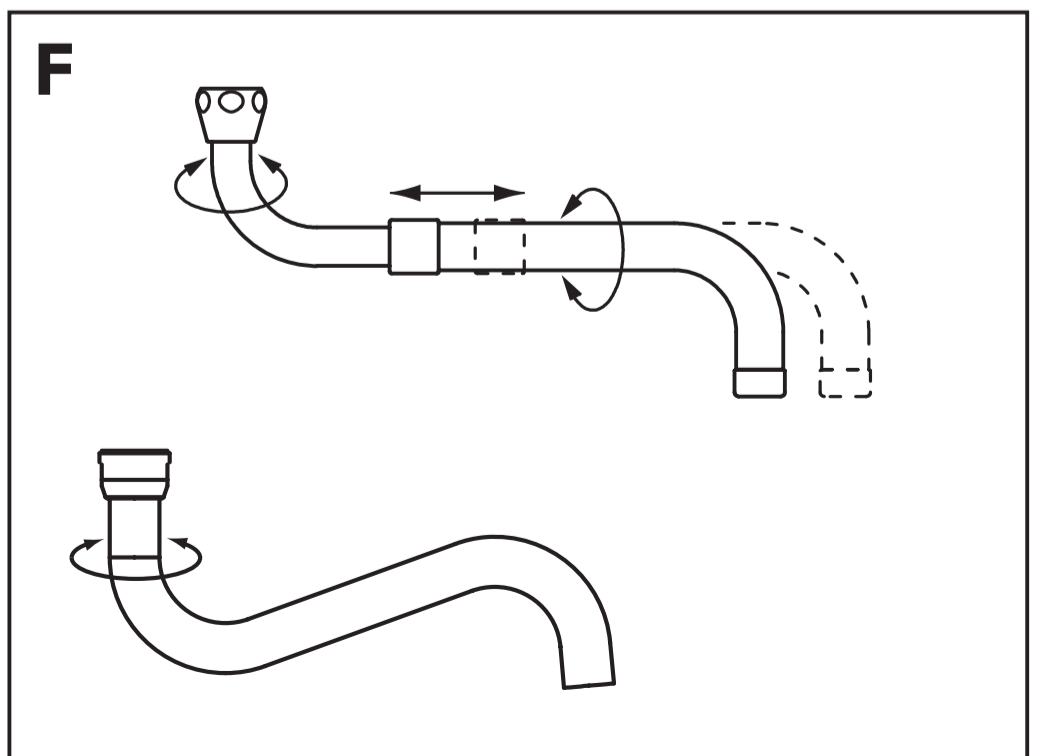
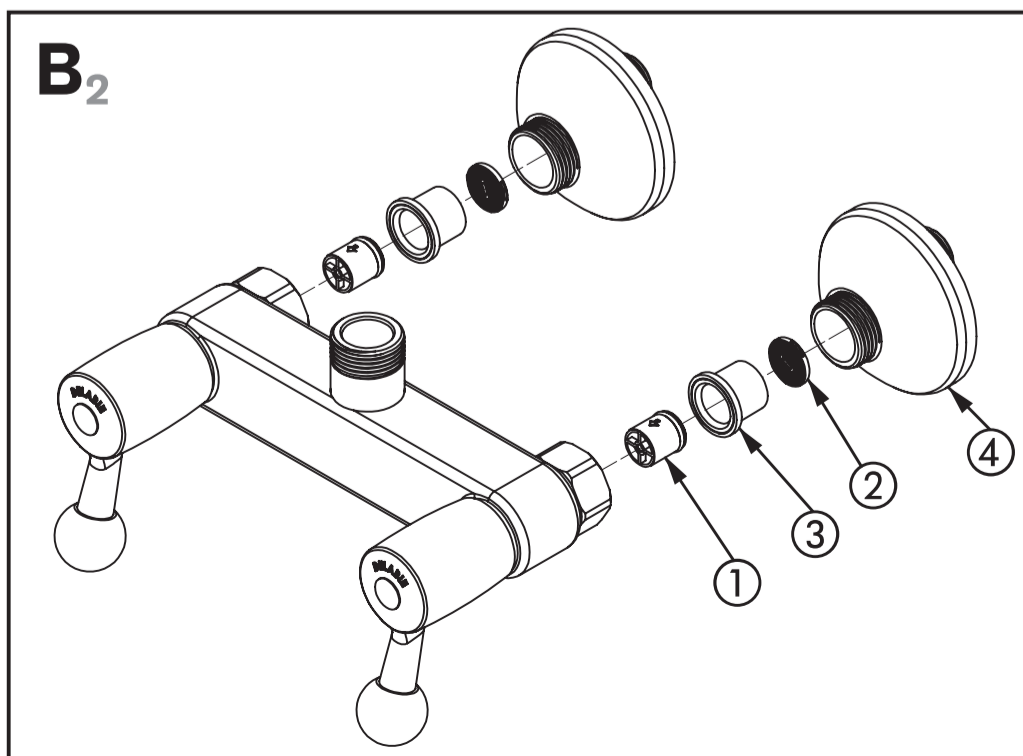
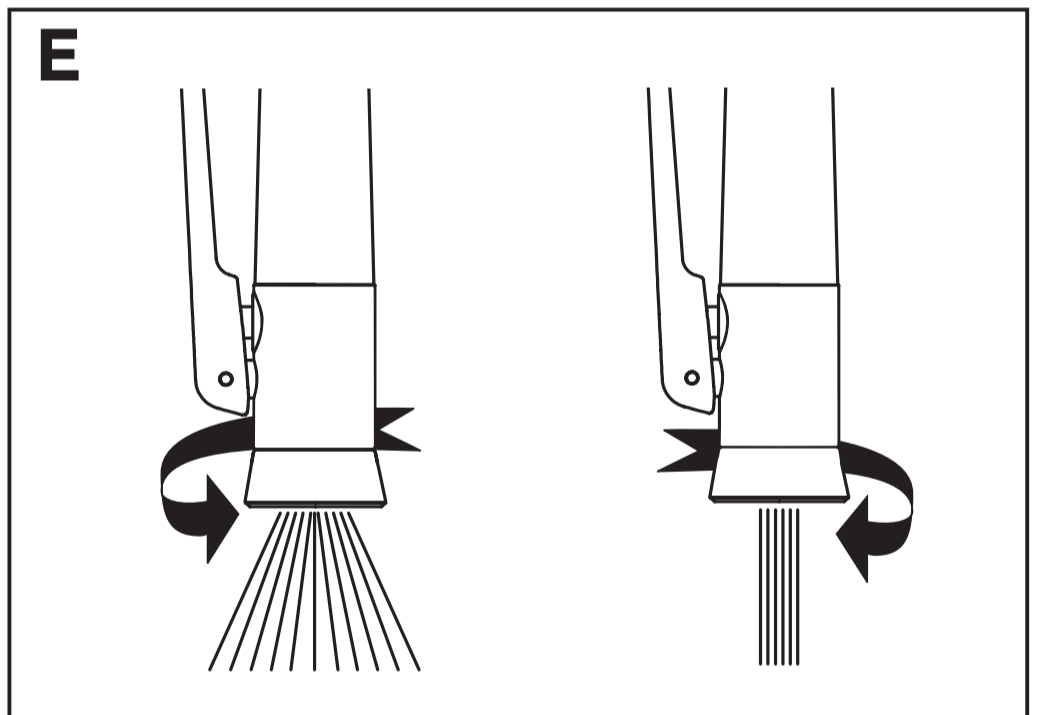
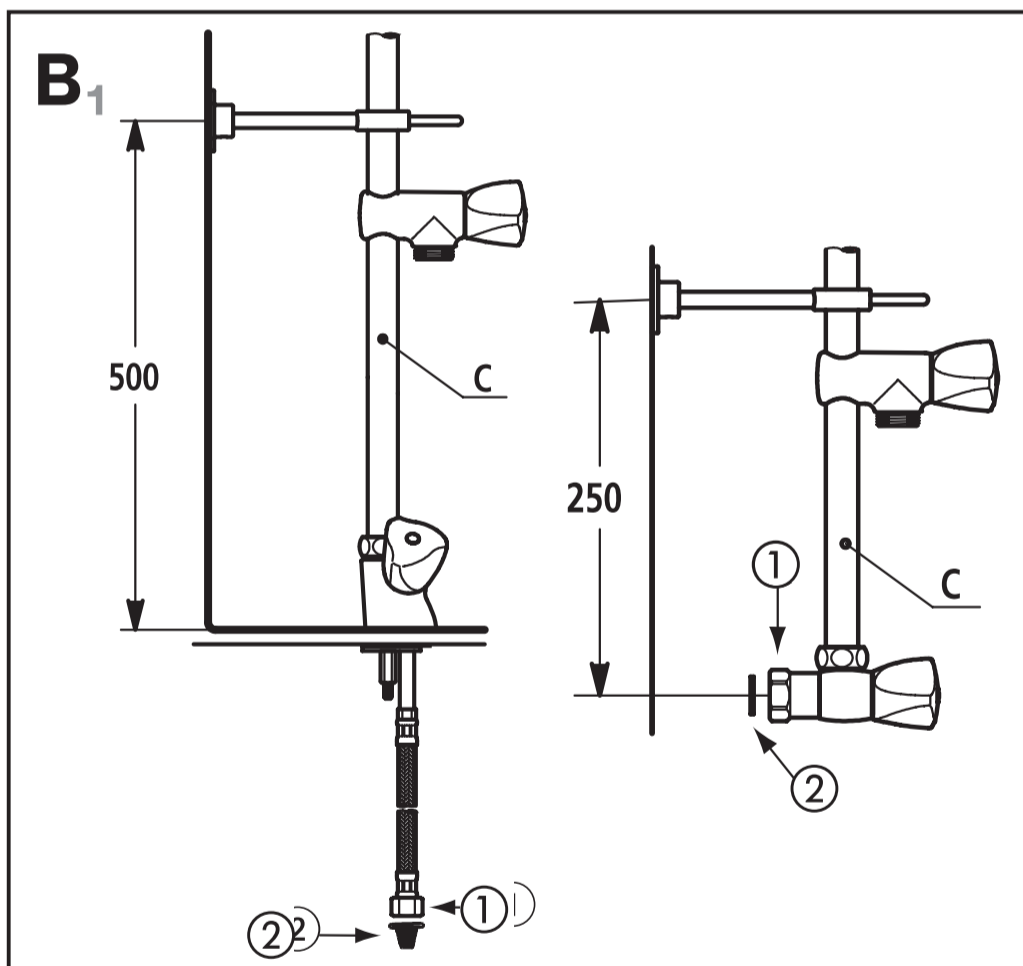
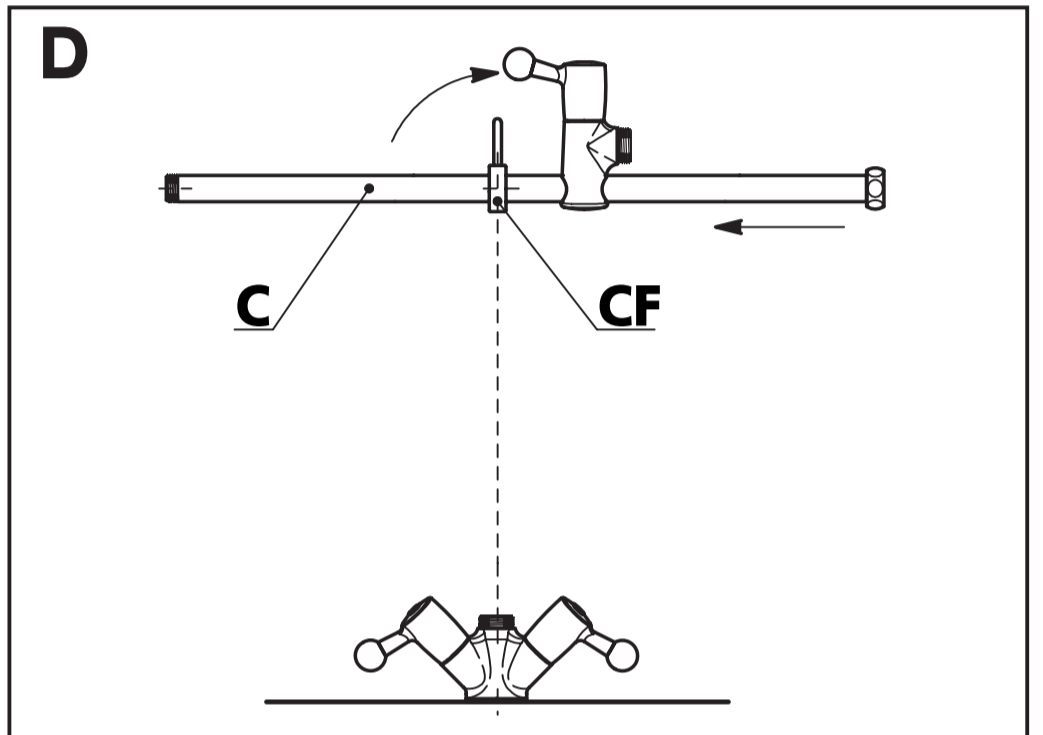
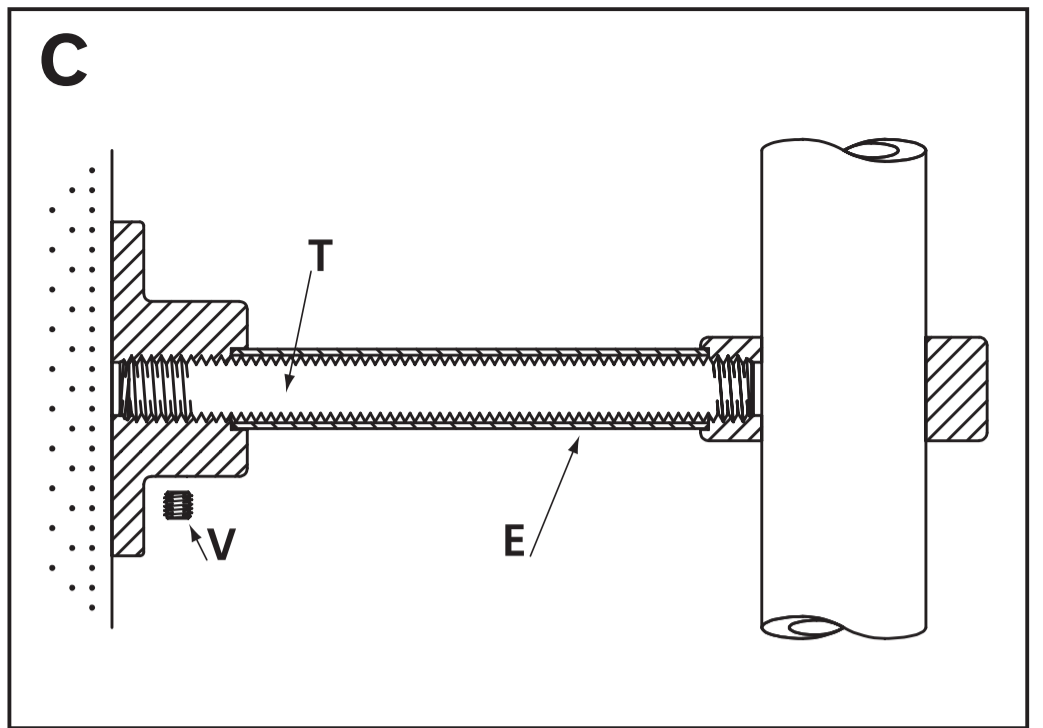
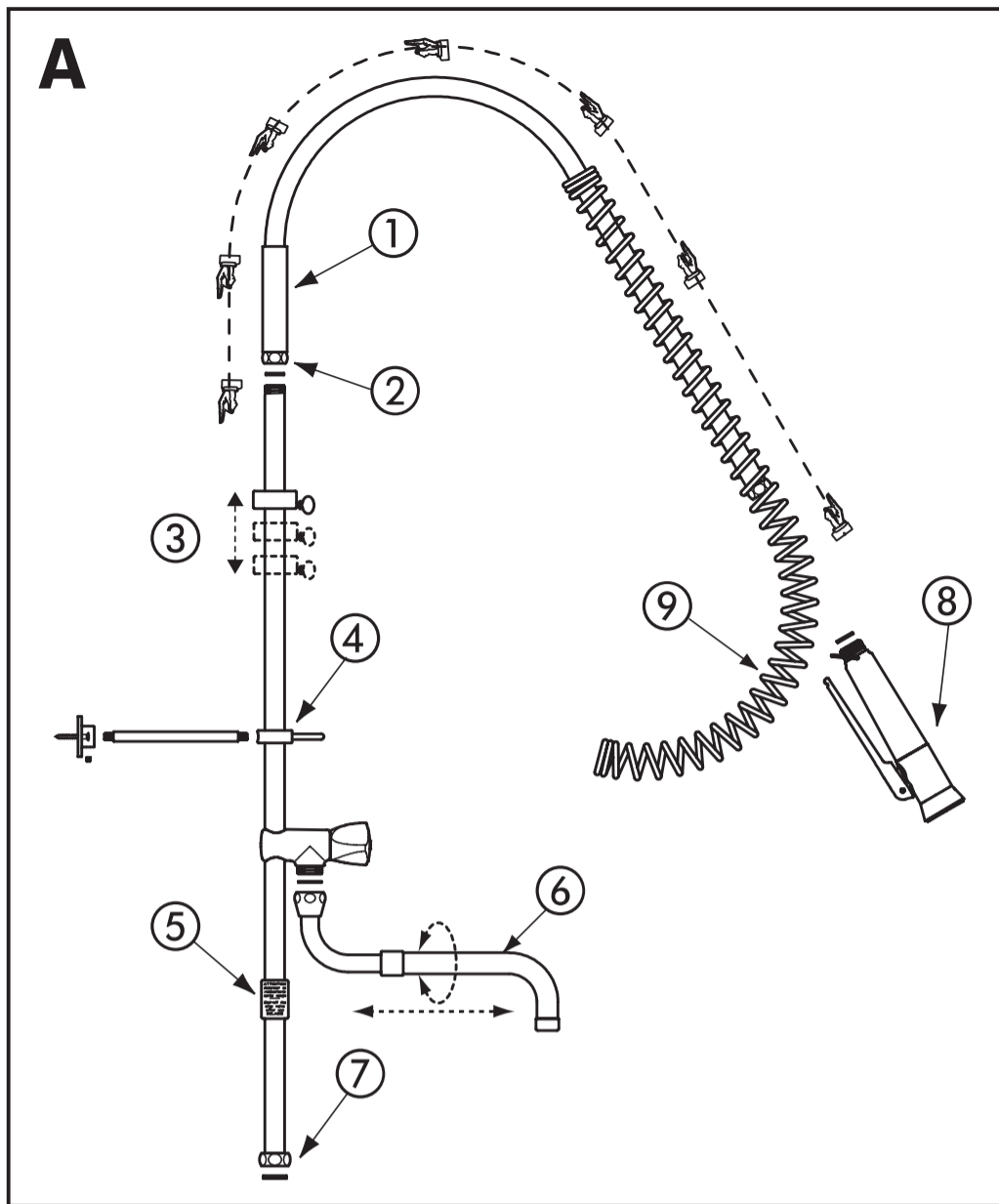

- Maximum supply temperature: 70°C.
- Maximum pressure: 5 bar.
- Flow rate: 16 - 25 lpm at the bib tap outlet (depending on the model).  
Flow rate at the hand spray outlet: rain effect (8 lpm at 3 bar) or concentrated jet (9 lpm at 3 bar).

## INSTALLATION (FIG. A, B, C & D)

### Installing the mixer or tap (Fig. B):

- single hole models: drill hole Ø 34mm on work surface.
- twin hole models: drill hole Ø 22mm.

Do not remove the non-return valves ① incorporated in the water inlets (essential).

Insert the filters supplied **exactly as shown in the diagram** ②, they will protect the non-return valves.

- models 5634 & 5636: insert the filters ② in the unions ④ (NB: make sure they are inserted all the way ④), insert the non-return valves ① in their casings ③ (take care to respect the direction of the arrows on the non-return valves ①), then insert ③+① into the unions ④ and assemble together with the valve (tighten with the spanner).

### Fixing the wall-mounted bracket (Fig. A-④ & B1):

- Deck-mounted: fix the mounting bracket 500mm above the work surface.
- Wall-mounted: fix the mounting bracket 250mm above the mixer.

Cut the threaded rod **T** to the desired length and adjust the chrome-plated spacer **E** to the desired length (**Fig. C**). Tighten the screw **V** using a 2.5mm Allen key.

Slide the riser column **C** into the mounting bracket **CF** horizontally. Turn through 90°, and tighten the riser column onto the mixer (**Fig. D**).

- The mixer/tap is supplied with a reinforced Hytel flexible hose 95cm long (**Fig. A-①**).  
If this flexible hose is not long enough, or it is not suitable (too much strain on the flexible), longer flexible hoses are available:
  - **Black flexible hose:** L. 1.20m (ref. 433120CH)
  - **White flexible hose:** L. 1.20m (ref. 433120) or L. 2.00m (ref. 433200).
- Screw the flexible hose onto the riser column with the reinforcement and rotating nut (**Fig. A-②**).
- Slide the spring support (**Fig. A-⑨**) onto the flexible hose. Make sure it is mounted the same way as the diagram: attach the right hand side first.
- Attach the hand spray to the other end of the flexible hose (**Fig. A-⑧**).
- Adjust the hand spray height using the adjustable spring guide (**Fig. A-③**).
- Attach the riser column to the mixer using the fixing nut (**Fig. A-⑦**).
- Supply with hot and cold water; balance the CW and HW pressure ( $\Delta P < 1$  bar).

## OPERATION

- Turn the hand spray on by pressing the trigger. Release the trigger to stop the flow. It is possible to lock the trigger in the open position using the collar. Turn the tip of the hand spray to adjust the jet shape and intensity: rain effect or concentrated jet (**Fig. E**).
- Depending on the model, the spout may be telescopic and swivelling, or tubular and swivelling (**Fig A-⑥ & F**).

- **Our mixers must be installed by professional installers** in accordance with current regulations and recommendations in your country, and the specifications of the fluid engineer.
- **Sizing the pipes correctly** will avoid problems of flow rate, pressure loss and water hammer (see calculation table in our brochure and online at [www.delabie.com](http://www.delabie.com)).
- **Protect the installation** with filters, water hammer absorbers and pressure reducers to reduce the frequency of maintenance (recommended pressure from 1 to 5 bar maximum).
- **Install stopcocks** close to the mixer to facilitate maintenance.
- The pipework, filters, non-return valves, stopcocks, bib taps, cartridge and all sanitary fittings should be checked at least once a year, and more frequently if necessary.

## SERVICING AND CLEANING

- **Cleaning chrome and stainless steel:** Do not use abrasive, chlorine or any other acid-based cleaning products. Clean with mild soapy water using a cloth or a sponge.
- **Frost protection:** Drain the pipes and operate the mixer/tap/valve several times to drain any remaining water. In the event of prolonged exposure to frost, we recommend taking the mechanisms apart and storing them indoors.